

Proposed Lafayette Square Historic Code Revision

An ordinance pertaining to the Lafayette Square Historic District; repealing Ordinance 63327, approved December 16, 1994 and having as its subject matter the boundary and regulations and standards for the Lafayette Square Historic District, and enacting in lieu thereof a new ordinance containing the boundary and standards of the Lafayette Square Historic District, and containing a severability clause.

Be it ordained by the City of St. Louis as follows:

SECTION ONE. Ordinance 63327, approved December 16, 1994 is hereby repealed.

SECTION TWO. Lafayette Square Historic District will be bounded by center median of Chouteau Avenue on the North, center median of Truman Parkway on the East, Highway 44 on the South and center median of Jefferson Avenue on the west.

Pursuant to and in accordance with Chapter 24 of the Revised Code of the City of St. Louis, the area set out below is hereby designated as a Historic District to be known as the Lafayette Square Historic District and shall consist of the area described as follows:

Chouteau Avenue at Truman Parkway's west curb, south to the south curb at Lafayette Avenue and Truman Parkway which includes H. Crossman's Subdivision in City Block 482E, property owned now or formerly by the Eden Partnerships; thence south along said east line of Lot 6, to a point of intersection with the north line of an east-west alley, 15 feet wide, in City Block 482E; thence southwestwardly to a point of intersection with the east line of a north-south alley, width varies, in City Block 482E; thence southwardly and along the east line of alley across all intervening streets and alleys to an intersection with the north line of Park Avenue, 80 feet wide, and the northwardly projection of the east line of a north-south alley, 20 feet wide, in City Block 1254; thence southwardly along the northwardly projection of the east line of said alley to a point of intersection with the east line and the south line of an east-west alley, 20 feet wide, in City Block 1254; thence westerly along the south line of the east-west alley to a point of intersection of the east line of Lot 6, Block 4 of 4th Subdivision of City Common's, in City Block 1254; thence southwardly and along the east line of Lot 6, Block 4 of 4th Subdivision of City Common's in City Block 1254, and crossing Carroll Street, 60 feet wide, and intersecting with the east line of Lot 20, Block 5 of 4th Subdivision of City Common's, in City Block 1254, and crossing Carroll Street, 60 feet wide, and intersecting with the east line of Lot 20, Block 5 of the 4th Subdivision of City Common's, in City Block 1253; thence eastwardly along the north line of alley to a point of intersection with the east line of a north-south alley, 20 feet wide, in City Block 1253; thence southwardly along the east line of north-south alley, to a point of intersection of the east line of said alley and the north line of an east-west alley, 20 feet wide, in City Block 1253; thence

eastwardly along the north line of the east-west alley to a point of intersection with the north prolongation of the east line of Lot 4, Block 5, 4th Subdivision of City Common's, in City Block 1253; thence southwardly and along the east line of Lot 4 a distance of 120 feet, more or less, to a point of intersection with the north line of Lafayette Avenue, 120 feet wide; thence across Lafayette Avenue to a point of intersection with the south line of Lafayette Avenue; thence westerly along the south line of Lafayette Avenue to a point of intersection with the east line of Eighteenth Street, 60 feet wide, said point also being the northwest corner of City Block 821N and also being a point in the north line of the right-of-way of Interstate Highway 44; thence westerly along the north line of the right-of-way of Interstate Highway 44, across all intervening streets and alleys to its point of intersection with the east line of Jefferson Avenue, 100 feet wide; thence diagonally northwestwardly along Jefferson Avenue to its intersection with the west line of Chouteau Ave. at Jefferson Avenue, then to the point of beginning along the south curb line of Chouteau Ave.“

SECTION THREE. The standards to be applied within the Lafayette Square Historic District, including but not limited to façades, setbacks, height, scale, materials, color and texture, for all structures and the design details of all fences, streets and drives, street furniture, signs and landscape materials, are set out in the "Lafayette Square Neighborhood – Urban Plan” (adopted December 5, 2002) a copy of which is attached hereto and marked as Exhibit A, are hereby adopted and incorporated herein by reference. Copies of said standards shall also be filed for inspection in the Office of the Register and in the Office of the Building Commissioner.

SECTION FOUR. SEVERABILITY CLAUSE If any provision, sentence, clause, section, part, or application of the ordinance and the regulations and standards contained herein is for any reason held to be unconstitutional, illegal, or invalid, such unconstitutionality, illegality, or invalidity shall not affect or impair any of the remaining provisions, sentences, clauses, sections, parts, or applications of this ordinance, regulations and standards.

TABLE OF CONTENTS

ARTICLE 1: INTRODUCTION

100 Preface

101 Definitions

ARTICLE 2: HISTORIC BUILDINGS

200 General

201 Roofs

201.1 Roof Lines and Dormer Configurations

- 201.2 Reconstructed Roofs
- 201.3 Roofing Materials on Sloping Roofs
- 201.4 Roofing Materials on Mansard Roofs
- 201.5 Brick Parapets
- 201.6 Dormers
- 201.7 Cornices
- 201.8 Roofing Accessories
- 202 Exterior Walls
 - 202.1 Exterior Masonry Walls
 - 202.2 Wood Siding
 - 202.3 Stone and Cementitious Stucco Façades
- 203 Windows
 - 203.1 Windows at Primary Public Façades
 - 203.2 Windows at Secondary Façades
- 204 Doors
 - 204.1 Doors at Public Façades
 - 204.2 Transoms at Public Façades
 - 204.3 Vehicular Doors
- 205 Foundations
 - 205.1 Paint
 - 205.2 Replacement Materials at Public Façades
 - 205.3 Surface Treatments at Public Façades
- 206 Appendages
 - 206.1 Location and Type of Appendages
 - 206.2 Stone Elements
 - 206.3 Wood Elements
 - 206.4 Metal Elements
- 207 Accessories
 - 207.1 Wrought and Cast-Iron Accessories
 - 207.2 Shutters at Public Façades
 - 207.3 Security Bars at Public Façades
 - 207.4 Awnings and Canopies
 - 207.5 Exterior Lighting at Public Façades
 - 207.6 Street Addresses at Public Façades
 - 207.7 Signs at Public Façades
 - 207.8 Mailboxes at Public Façades
- 208 Modern Conveniences and Utilities
- 209 Storefronts
 - 208.1 Reconstructed Storefronts
 - 208.2 Storefront Conversion
- 210 Carriage and Alley Houses

209.1 Primary Façades

211 Rehabilitation of Non-Historic Buildings

ARTICLE 3: NEW CONSTRUCTION AND ADDITIONS TO HISTORIC BUILDINGS

300 General

301 Additions to Historic Residential Properties

302 New Appendages

303 New Residential Construction Based on an Historic Model Example

303.1 Historic Model Example

303.2 Site planning

303.3 Massing and Scale

303.4 Proportions and Solid to Void Ratio

303.5 Exterior Materials and Color

303.6 Windows

303.7 Doors

303.8 Cornices

303.9 Roofs

304 New Non-Residential New Construction

304.1 Site Planning

304.2 Massing and Scale

304.3 Proportion and Solid to Void Ratio

304.4 Exterior Materials and Color

304.5 Windows

304.6 Roofs

305 New Garages

306 Alley Houses and Carriage Houses

ARTICLE 4: SITE

401 Slope and Grade of Public Yards

402 Walls

402.1 Freestanding Walls

402.2 Retaining Walls

403 Fences

403.1 Street Fences

403.2 Privacy Fences

404 Sidewalks

405 Exterior Lighting at Public Façades

406 Lawn Sculpture

407 Swimming Pools

408 Satellite Dishes

409 Mailboxes

ARTICLE 5. DEMOLITION

500 Applications for Demolition Permits

501 Valid Reasons for Demolition Permits

502 Invalid Reasons for Demolition Permits

ARTICLE 6 VACANT BUILDINGS

ARTICLE 7 BUILDING PERMITS

EXHIBIT A: “Lafayette Square Neighborhood – Urban Plan”

EXHIBIT B: Figures Referenced Throughout This Document

EXHIBIT C: Plat of the Lafayette Square Historic District

ARTICLE 1: INTRODUCTION

100 Preface

The Lafayette Square Historic Code has been developed to establish a consistent and understandable set of standards to govern the development of the Lafayette Square Historic District. This Ordinance supplements the City of St. Louis Building Code and regulates the construction, maintenance and repair of buildings and their surroundings within the District.

The Lafayette Square Historic District is unique to the City of St. Louis in its character, size and quantity of relatively unaltered historical buildings. The neighborhood is distinct for the manner in which the historic buildings relate to one another and to the street. The physical characteristics of the District as well as the importance of the neighborhood in the historical development of the City of St. Louis are compelling reasons for preserving and controlling these special features. Additionally, the historical value of the district has great economic value. Through establishment and enforcement of controls over the architectural characteristics of the District, property owners are ensured of the on-going historical value of the neighborhood while allowing for planned growth and development.

There are two basic concepts inherent in this Historic Code. They are embodied in the definitions of Public and Private Façades, and Historic Model Example. By establishing a definition for two types of building façades, there is also established the idea that certain portions of a building are more critical to the neighborhood's character than others. Based on this premise, this Ordinance regulates more stringently the "Public" elements of the district and is less concerned with the relatively private elements.

The use of an Historic Model Example (HME) as a requirement for the reconstruction of building elements of residential buildings or new residential construction has an important advantage. By using the district itself as a source of design and detail, the relationship of a reconstruction or new construction of a building will maintain the historical character of the district.

This version of the historic district standards integrates accessibility provisions for people with disabilities to commercial properties and other places of public accommodation. These standards encourage the provision of accessibility to private residences, seek to avoid increasing the instances where accessibility is not possible, and recognize that accessibility can be accomplished without compromising the historic integrity of historic buildings and the neighborhood. These standards shall not be used to claim exemption from accessibility requirements mandated by city, state or federal law. In a similar manner, these historic district standards shall be met when changes are proposed for accessibility. Both goals of retaining historic integrity and accessibility for people with disabilities can be met through the use of sophisticated design solutions.

These standards address common situations and are not intended to address every eventuality that may occur. The interpretation of these standards shall recognize that due to the physical nature of a property, the historic arrangement of buildings on a property, the historic use, a proposed new use, and other factors, instances could arise that the

literal interpretation of one or more components of these standards would result in a hardship for a property owner. In these instances, the intent of the ordinance that designated the historic district and these standards shall guide decision making.

101 Definitions

1. **Accessible Route**
A continuous unobstructed path.
2. **Alley House**
Residential structures built at the rear of a building lot are called alley houses. In the early days of the neighborhood, this double-loading of a building lot was a way to provide more living space, whether for extended family, rental property or buildings for sale. Today some alley houses are the only building remaining on the lot; others have been converted into garages or storage buildings.
2. **Ancillary Structure**
Ancillary buildings are detached, non-habitable structures including, but not limited to, the following: gate houses, common mailbox centers, storage sheds, greenhouses and garages.
3. **Appendage** (See figure 1)
An accessory space, enclosed or unenclosed, single-story or two-story attached structure; i.e. conservatory, covered porch, balcony, accessibility ramp. This definition does not include decks, uncovered porches or room additions.
4. **Cast Iron** (See figure 19)
Term used to describe a method of manufacturing iron parts or certain building elements. The iron is heated to a molten state and poured into molds. Decorative tips and tie-rod stars are two common examples of cast-iron.
5. **Carriage House**
In the District there are many carriage houses; usually they are located at the rear of the building lot immediate to the alley. A carriage house is most often a two-story structure. The ground level was used to protect carriages and horses and the attic story was used to store feed. Carriages typically entered from the rear (alley) and the front of the building (facing the rear of the main house) contained a door for human entrance and egress. Living quarters were frequently incorporated into the structure for the driver, or hired hand.
6. **Coping** (See figure 4)
The cap of a parapet or wall.
7. **Cornice** (See figures 1, 3, 5 & 6)
This is the decorative portion of a building located where the building wall meets the roof. Besides being a decorative element, the cornice often camouflages the

gutter and supports the roof overhang. In the district, cornices are made of a variety of materials and designs incorporating brackets, dentil moldings, and ogee moldings.

8. **Dormer** (See figures 1 & 20)

A structure built upon a sloping roof or mansard to provide a window into the attic story.

9. **Eyebrow**

The wood panel that fills in the transition between an arched brick lintel and a flat window head.

10. **Facade** (See figure 1)

A building façade is an outer wall of a structure. Façades are distinguished by their architectural presence as primary, secondary, and rear.

Primary façades establish the architectural character of the building and are street-facing and therefore public façades as well.

Secondary façades have less architectural character than primary façades and are typically side walls of a building. Secondary façades that face the street are also public façades; those that do not were intended to be private façades. However, secondary façades that are now more than 4 feet from an adjacent building are visible from public areas and are consequently considered to be public façades.

Rear façades often have a more utilitarian appearance and role, and generally are not meant to be seen from a street. They are private façades.

10.1 Primary Public Façade

A primary façade that directly faces a public street.

10.2 Private Façade

As this ordinance distinguishes between public and private areas of properties, private façades are those that are not visible from the street. These include rear, alley-facing façades and side façades separated by a maximum of 4 feet from adjacent buildings.

10.3 Secondary Public Façade

A side exterior wall that faces directly onto a street. Secondary public façades include those sections of the walls that are recessed. Secondary façades that are more than 4 feet from an adjacent building are visible from public areas and are therefore considered to be public façades.

10.4 Secondary Private Façade

A side exterior wall that does not directly face a street and is separated by no more than 4 feet from an adjacent building.

11. **Finish Materials**

Any smooth surfaced wood painted or stained, brick or stone are considered finish materials. Unpainted copper, lead, or brass is also permitted. Other materials including, but not limited to, bare metal, unpainted galvanized metal, rough sawn wood, and bare Wolmanized wood are not considered finish materials.

12. **Flat Roof**

Flat roofs in the district are those that are essentially flat. They will usually have a slope of 1/4 inches per foot to 1/2 inches per foot and are almost always waterproofed by a built-up roof.

13. **Free Standing Wall**

A wall approximately the same height above the grade on each side of the wall.

14. **Gable Face**

The gable of a building is the triangle portion of a building wall that is formed by two slopes of a roof.

15. **Half-Flounder**

A type of building that has a roof that slopes from one side of the building to the other, as opposed to sloping to the front or back.

16. **Hip Roof**

A roof in which all four sides slope upward.

17. **Historic**

As used in this Ordinance, the word "historic" describes a building that was built in ~~1898-1919~~ or before. This age distinction helps to identify buildings within the District that deserve the strictest protections. A building being rehabilitated, repaired or receiving a new addition is regulated differently by this Ordinance if it is "historic" in the context of this definition. Existing buildings that are not historic are also affected by various provisions of this Ordinance.

18. **Historic Model Example [HME]**

An Historic Model Example (HME) is a residential building or element(s) of a single residential architectural type and style selected for use as a guide for the design of a reconstructed element or new residential building. In this Ordinance, an HME always means a residential building erected before 1898 within the district; it must be an unaltered building or unaltered feature or that building that is being replicated.

1. Requirements for a Historic Model Example. Change to A-C below and after 2

1. The Cultural Resources Office shall approve the selected HME for each project to make sure that it is an appropriate example.
2. When an HME is cited for an element to be reconstructed on an historic structure, it shall be an historic building or component of a building of comparable age, form, and architectural style to the proposed project.

3. Alterations and additions to a historic residential building that meet the criteria of "historic" may be used as an HME

~~4. When an HME is cited for new construction, it will be a building in the vicinity of the parcel to be built on.~~

2. HMEs shall be presented in the following forms:

1. Existing buildings or building elements shall be photographed; minimally 3 inches x 5 inches, black and white or color. Elements shall be photographed in detail, and from at least two angles. Elements shall be accompanied by a photo illustrating the overall form and architectural style of the building.
2. Photographs of buildings or building elements no longer in existence.

19. **Mansard** (See figure 3)

A mansard is a steeply sloped roof that allows for more usable room in an attic story. Usually a mansard roof is used to mask a building's third story and in this way, the building appears to have only two stories capped with a roof. The mansard roof may be used to make a building look taller or more impressive. Dormers were often incorporated to provide light and ventilation for the attic story.

20. **Masonry**

Masonry is the family of building materials that use stone, brick, ceramic or concrete block units, usually separated by mortar beds and joints. Exterior stucco is included in the family of masonry.

21. **Mass**

The visual displacement of space based on a building's height, width and depth; the three dimensional impact of a structure.

22. **Modern Convenience**

A term used to describe features on houses that did not exist in Victorian times and are now common features of houses, including but not limited to: air-conditioning condensers; radio or television antennas or dishes; plumbing vent stacks; kitchen vents; utility meters (gas, electric, water); electrical outlets; television cable wires; electrical wires; exterior gas pipes; exterior water pipes; telephone wires; corrugated rain spouts; furnace exhaust; water faucets; wooden platform patios; decks; hot-tubs; in-ground pools; fountains; skylights; pergolas; permanent fire pits, ovens or barbeques; rain barrels; landscape water features; solar panels; and greenhouses.

23. **Non-Historic Building**

A building existing in the Lafayette Square Historic District constructed after ~~1898~~1919.

24. **Parapet** (See figure 4)

A building's parapet is that portion of its walls that project above the roof. Parapets are most commonly part of a masonry building and can be found on buildings with flat, gabled, half-flounder, and mansard roofs.

25. **Permastone**

Permastone is a trade name that has come to be used generically to describe all varieties of synthetic materials designed to resemble stone. These materials are precast cementitious "stones" or panels of "stone" attached as veneer over existing materials.

26. **Cementitious Stucco Veneer**

A stucco veneer application of a soft cementitious material applied to the entire façade of a building and scored to appear as stone.

27. **Primary Public Façade**

A primary façade that directly faces a public street.

28. **Private Facade**

As this ordinance distinguishes between public and private areas of properties, private façades are those that are not visible from the street. These include rear, alley-facing façades and side façades separated by a maximum of 4 feet from adjacent buildings.

29. **Private Yard**

That portion of a lot that is not visible from an adjacent public street because it is concealed by the main building, adjoining properties, and/or privacy fences. It typically extends from the main building to the alley or to an alley house, carriage house, or garage, and must have one of the following on each of its sides:

1. The private facade of the main building;
2. The private facade of a building on an adjoining property;
3. The private yard of an adjoining property;
4. An alley;
5. A carriage house, alley house, or garage;
6. A privacy fence.

30. **Privacy Fence**

An opaque fence that encloses a private portion of a yard.

31. **Proportion**

A system of mathematical ratios that establish a consistent set of visual relationships between the parts of a building and to the building as a whole.

32. **Public Yard**

That portion of the lot that is between the primary public facade and the street it faces, and that is visible from public sidewalks and streets. A side yard on a corner property not enclosed with a privacy fence is also a public yard.

33. **Ratio of Solid to Void**
The percentage of opening to solid wall. Openings include doors, windows and recessed porches and vestibules.
30. **Retaining Wall**
A wall constructed to allow a change in grade from one side of the wall to the other.
31. **Scale**
The perceived size of a building relative to the height and width of adjacent structures. Also the perceived size of an element on a building relative to a known architectural elements, for example, the size of a door relative to a window.
32. **Secondary Private Facade**
A side exterior wall that does not directly face a street and is separated by no more than 4 feet from an adjacent building.
33. **Secondary Public Facade**
A side exterior wall that faces directly onto a street. Secondary public façades include those sections of the walls that are recessed. Secondary façades that are more than 4 feet from an adjacent building are visible from public areas and are therefore considered to be public façades.
34. **Side Yard**
A side yard is land used as a private yard. This land is typically in addition to the basic 25' wide lot, as is common in Lafayette Square. For the purposes of permitting materials and design for new construction or historic rehabilitation, the side yard may be owned by either the petitioning owner or the adjacent resident.
35. **Storefront**
Storefronts consist mainly of large, fixed pieces of glass as typified by figure 11. Storefronts are generally tripartite with a bulkhead, shop window and transom above. The glazing area normally extends from a knee-high sill to ceiling height, with wood or metal frames supporting the store window and transoms.
36. **Street Fence**
A fence located in front of the building or less than 12 inches behind the building line.
37. **Primary Public Facade**
The exterior wall of building that fronts directly on a public street and therefore is a critical visual element in the district and public due to its visibility.
38. **Tooth-In**
A masonry technique used to form a new opening or close an existing opening in a masonry wall. In the case of a new opening in a brick wall, the edges of the new opening would first be notched beyond the actual width dimensions of the opening.

This notching would allow for the insertion of half bricks aligning with the ends of the full bricks. The result is an opening jamb that is smooth, neatly aligned, and has the hard surface of the bricks properly exposed at the jamb edges. The reverse process would be used to brick in an opening in an attempt to blend the new bricks with the existing. This reverse process is not a recommended method of infilling a window under this Ordinance. Proper methods are described in Article 203.2(C)

39. **Top Cornice or Crown Molding**
An ornamental molding of wood with sheet metal flashing or entirely of sheet metal that defines the top edge of the finish material of a mansard roof and which covers the seam between this material and that of the roof.
40. **Tuckpointing**
A process of repairing mortar joints in a masonry wall. The existing mortar is removed to a prescribed depth from the face of the masonry. After this process is complete, new mortar is pressed into the joints and then properly tooled. The removal process is important to provide adequate area for the new mortar. The mortar mix must be compatible with the hardness of the masonry. The color of the mortar is determined by pigments added, the type, size, and quantity of sand mixed in, and the color of the cement used. The tooling of the mortar joint is important because the design of the joint tooling can affect the ability of the joint to shed water (See figure 8). The design of the joint tooling also affects the appearance of the masonry.
41. **Vacant Lot**
A vacant lot is a buildable lot available for development. It is a property that is not currently being used as a community garden or other community use that is likely to be long term.
42. **Visible**
For the purpose of this **code**, visibility shall be determined from public areas such as streets and sidewalks. Visible shall refer to the condition of being seen from public areas, when viewed from six feet or less above the ground. Landscaping is not permanent and shall not be considered when determining visibility. Fences and free-standing walls are considered permanent, and objects hidden by fences and free-standing walls shall be considered not visible.
43. **Wythe** (See figure 7)
A term used in masonry construction to describe the thickness of a wall. A two wythe brick wall is one that is two bricks thick (approximately 8 inches). Most brick walls in historic residential construction are three wythe walls or three bricks thick (approximately 13 inches).
44. **Wrought Iron**
A term used to describe a method of manufacturing iron parts or certain building elements. The iron is heated in a forge and shaped while soft, either by bending or

hammering. Fences and gates often incorporate wrought iron elements. (See figure 19)

ARTICLE 2: HISTORIC BUILDINGS

200 GENERAL:

- 200.1 If documented evidence can be provided that verifies that an element of an existing building has been altered, it may be reconstructed to its original configuration and its original materials.
- 200.2 If a building was built after ~~1898~~1919, it is not an historic building within the meaning of this Ordinance and will be regulated under Section 210.~~—~~ Evidence that the building, addition or element was built after ~~1898-1919~~ must be provided.
- 200.3 When a choice of solutions is given in this Ordinance, the solutions are presented in order of preference.
- 200.4 The materials ~~that are choices~~ approved and prohibited in this ordinance reflect general acceptability for the use of substitute materials at the time this ordinance was adopted. The intent is not to prohibit the use of additional or new products and materials that replicate historic elements and materials as they become available. The Cultural Resources Office, in consultation with the Preservation Board and the Lafayette Square Restoration Committee, will determine when additional materials are appropriate and can be approved.
- 200.5 ~~Certain~~ Repairs to elements or features of a historic building not explicitly addressed by may be made outside the scope of this Code ~~these Standards may be made~~ if all of the following conditions are met:
- A] The element or elements are not historic.
 - B] The element or elements to be repaired are part of an identical ~~matched~~ set of elements and that constitute 50 percent or less of the total set, the remainder of which do not require repair. Situations that meet these criteria are re-touching of existing paint, repair, re-glazing or replacement of one of a set of four matched windows, replacement of missing shingles, etc.
 - C] The appearance of the repaired or replacement element matches that of the non-repaired elements.
 - D] The existing appearance of the building is not altered.

201 Roofs

Comment: Roofs are prominent parts of buildings, and in conjunction with the walls determine a building's form and scale. Roof styles, the condition of the roof and its details greatly influence the visual character of the district. Most of the roof styles in the district fall into one of the following categories: mansard; gable; hipped; or flat.

201.1 Roof Lines And Dormer Configuration

The roof lines and dormer configuration of an historic building shall not be altered except as specifically permitted in this Ordinance. Roof lines include the roof's slope, height, present location and structure. A dormer configuration includes its form, dimensions, roof shape, and materials.

201.2 Reconstructed Roofs

Reconstructed roofs shall be based on the original roof design. Where the original slope of the roof cannot be verified through reasonable research or existing evidence, an HME may be used.

201.3 Roofing ~~Materials~~ On Sloping Roofs

Comment: Sloping roofs include all roof types except mansard roofs, which are addressed in Section 201.4 and flat roofs, which are not regulated.

A] Roofing materials on sloping roofs shall be one of the following:

- 1) A material that can be documented as being original to the building;
- 2) Slate shingles;
- 3) Synthetic slate shingles made of a cementitious composition with fiberglass reinforcing or polymeric material;
- 4) A composition shingle that replicates the proportions of slate shingles;
Comment: GAF "Slateline" fulfills this requirement
- 5) Asphalt or fiberglass composition shingles, standard three tab design of 235 pounds per square minimum construction;

B] Roll roofing and roofing felt, sheet metal, wood shingles and vinyl are prohibited as finished roofing materials on sloping roofs (though acceptable on "flat roofs").

C] Patterns may not be arranged in roofing materials on sloping roofs unless based on evidence original to the building.

201.4 Roofing ~~onMaterials On~~ Mansard Roofs

A] Slate or synthetic slate must be used to replace missing or damaged shingles on mansard roofs where more than 50 percent of the original slate shingles are in existence.

B] Patterns on mansard roofs:

- 1) Patterns created by the arrangement of slate of differing colors or configurations shall not be altered.
- 2) Patterns shall not be painted where no pattern originally existed.
- 3) Patterns shall not be repainted or re-stained where they have faded.

- 4) Reconstructed mansard roofs may be patterned through the use of slate or synthetic slate shingles of differing colors or configurations. Such patterns are allowed only if based on evidence original to the building.
 - 5) Mansards on which the slates are being replaced may have a slate pattern that conforms to an HME if no original pattern can be documented.
- C] Roofing materials on mansard roofs shall be one of the following:
- 1) A material that can be documented as being original to the building;
 - 2) Slate shingles;
 - 3) Synthetic slate shingles of a cementitious composition with fiberglass or asbestos reinforcing;
 - 4) Mansard roofs with composition shingles may continue to be covered with new composition shingles, though slate or synthetic slate shingles are more sympathetic to the original character of the building.
- D] Roll roofing and roofing felt are prohibited as finished roofing materials on mansard roofs.

201.5 Brick Parapets (See figure 4)

- A] Brick parapets and the manner in which the roofing material meet them shall be treated as follows:
- 1) When the inside face of the parapet is visible from the ground, the roofing material shall be flashed and counter-flashed with sheet metal set into the masonry parapet wall.
 - 2) When the inside face of the parapet is not visible from the ground, the roofing material may be extended up the inside face of the parapet and fitted under the metal flashing or the parapet cap.
 - 3) Felt, roofing paper or roll roofing is prohibited as finish material at the visible side of parapets.
- B] Parapet coping shall be restricted as follows:
- 1) Visible coping on sloping and horizontal parapets must be made of one of the following: glazed coping tiles, copper, factory-finished, colored aluminum, lead, or tern metal.
 - 2) No other variety of sheet metal coping shall be visible.

Comment: Metal or plastic through-wall flashing should be used to prevent moisture from penetrating the masonry.

201.6 Dormers (See figure 20)

- A] Dormers shall not be removed or altered in configuration, location or detail.

B] Replacement dormers and elements of a dormer shall be designed and positioned on roofs to replicate the dimensions, proportions, materials and details, including ornament, of the original dormers. Where such dimensions, proportions, materials or details are not evident from existing conditions, an HME must be provided. New materials that replicate the original materials shall be used.

C] Dormers are prohibited where there is no evidence of their prior existence.

D] Dormer Materials

Comment: The sides of dormers on slate roofs are typically slate, while the sides of dormers on asphalt shingle roofs are typically - inch exposed wood siding. (See figure 10 for illustration of 4 inches exposed wood siding)

1) Dormer materials, including those at the sides, shall not be altered in appearance and scale from the original, except that non-wood siding may be used at the sides when the dormer is located above the second story of a building.

2) Vinyl is not an acceptable material for dormers.

E] Ornament at Dormers

Comment: The role of ornament at dormers is architecturally significant.

1) If missing, dormer ornament must be replicated from historical evidence at the dormer(s).

2) Where such evidence no longer exists, ornament shall be replicated from an HME.

3) Replacement ornament must be constructed of original materials or other material that replicates the original appearance.

4) Ornament and dormer detailing must be of a finished material. See Finish Materials, Section 101.10.

201.7 Cornices (See figures 5 & 6)

Comment: Cornices are a critical element of a building's historical and visual integrity. Cornices, including top cornices and crown moldings, are typically constructed of brick, built-up pieces of wood, or sheet metal, or a combination of materials.

A] Reconstructed cornices shall be designed to replicate the dimensions, including length of corner returns, proportions and details of the original cornice. Where such dimensions, proportions and details are not evident from existing conditions, an HME shall be replicated.

B] Cornice Materials:

1) Cornice materials shall not be altered from the original except as permitted in this Ordinance.

2) Replacement materials shall duplicate the appearance of the finished original materials. See Finish Materials, Section 101.10.

- 3) Replacement brick within a cornice shall be of similar dimensions, color and surface characteristics as the original.
 - 4) Ornamental pressed brick: replacement sections of ornamental pressed brick within a cornice shall be of one of the following:
 - (a) New or used pressed brick of similar dimensions, color and surface characteristics as the original.
 - (b) Fiberglass reinforced concrete replicas with integral color and matching the original in color and surface characteristics.
 - 5) Sheet metal: replacement sections of sheet metal within a cornice shall be of one of the following:
 - (a) Sheet metal of the same material as the existing sheet metal.
 - (b) Any of the materials indicated as appropriate for use within wood cornices.
 - 6) Wood: Replacement sections of wood within a cornice shall be of one of the following:
 - (a) Wood.
 - (b) Fiberglass replicating the original wood.
 - (c) Synthetic molded replicas of the original wood.
 - 7) Stone and terra cotta: replacement sections of stone or terra cotta shall be of one the following:
 - (a) Stone or terra cotta of similar color, texture and dimension as the original.
 - (b) Precast concrete of similar color, texture and dimension as the original.
 - (c) Fiberglass reinforced concrete replicating the original
 - (d) Molded synthetic replicas of the original stone or terra cotta.
- C] Gutters within a Cornice: (See also Section 201.8 (A) Gutters and Downspouts)
- 1) If necessary, wood and metal cornices with built-in gutters shall be rebuilt in one of the following methods:
 - (a) Reconstructed to match the original in profile, material and dimension. The method of drainage shall be similar to the original. (See figure 5)
 - (b) Reconstructed with a standard sheet metal gutter section integrated into the cornice profile and maintaining the height and projection of the original. (See figure 6)
 - (c) An acceptable alternative is to install a revised cornice and gutter assembly that incorporates the gutter into the design so that it does not appear to be a separate element.

Comment: The section of a standard sheet metal gutter is not always sufficient to accommodate the volume of water shed from many historic roofs. For this reason, the area drainage volume should be determined and the gutter sized accordingly.

- 2) Masonry cornices with built-in gutters may be reconstructed to match the original in design, profile, dimension and detail.
- D] Cornice Finish: All exterior surfaces of a cornice shall be painted except copper, which may be allowed to obtain its natural oxidized finish.

201.8 Roofing Accessories

A] Gutters and Downspouts:

- 1) New gutters and downspouts shall be similar in location, shape, detail and size of the original or HME and shall be connected to the sewer system.
- 2) If no original location is evident, gutters across the façade shall return around corners to side facade and downspout shall be located on the side facade.
- 3) Gutters on the primary public façade must be incorporated into a cornice design based on an HME so that the gutter is not visible as a separate element. No gutters can be placed as individual elements across the primary public façade.
- 4) New gutters and downspouts shall be of one of the following materials:
 - (a) Copper; painted or allowed to oxidize.
 - (b) Galvanized metal, painted.
 - (c) Aluminum, factory-finished as a non-reflective surface.
- 5) Plastic gutters and downspouts are prohibited.

B] Chimneys (See figure 12)

- 1) Existing chimneys shall be retained.
- 2) Chimneys not in use may be capped in a manner similar to adjacent parapets, but in no case is a chimney to be altered in dimension, including height.
- 3) Reconstructed chimneys shall duplicate the original or be based upon an HME.

C] Roof Cresting (See figure 1)

- 1) Roof cresting shall not be removed or altered in configuration, location or detail.
- 2) Roof cresting shall not be added to a building where there is no evidence that it existed historically.

- 3) Replacement roof cresting shall be designed and positioned on a roof to replicate the dimensions, proportions, materials and details of the original roof cresting. Where such dimensions, proportions, materials or details are not evident from existing conditions, an HME must be replicated.
 - 4) Roof cresting shall be of the following materials:
 - (a) Wrought iron, cast iron, copper or other non-reflective metal.
 - (b) Plastic that replicates the appearance of the above. Plastic cresting shall be securely attached and rigid so as to be indistinguishable from metal cresting.
- D] No plumbing vent stacks, attic ventilation devices, metal chimney flues or metal fireplace chimneys shall be visible, except that one roof penetration may be allowed for a plumbing vent on a sloping roof where it is impossible to hide such from view.
- E] No skylight or roof window shall be visible.
- F] No radio or television antennae or satellite dish shall be visible.
- G] No solar collectors shall be visible.
- H] No roof decks on top of the uppermost story of a structure shall be visible.
- I] No roof-top air conditioning units shall be visible.
- J] No other items that are not original to a structure shall be visible.

202 EXTERIOR WALLS

Comment: Exterior walls are the physical means of enclosing space beneath a roof. Exterior walls also define the shape and visual character of a building and in conjunction with the roof, determine the mass and scale of a building. Most exterior walls in the district are brick masonry of double or triple-wythe construction. A large number of the masonry walls at primary public façades have stone or cementitious stucco veneers detailed to appear as stone.

Exterior walls of all types of construction form a building's primary structure. Structural damage is most often related to water penetration. For this reason exterior walls, and openings within the wall, shall be maintained and protected in order to assure the longevity of the structure.

202.1 Exterior Masonry Walls

- A] Cleaning existing exterior masonry
- 1) The blasting of exterior masonry walls with sand or other abrasive materials is prohibited.

Comment: Blasting a masonry wall with abrasive materials destroys the hard outer surface of the masonry and thus exposes the softer core of the

masonry to the elements. Blasting thus not only permanently damages the appearance of the brick, but also shortens the life of the individual brick and the building as a whole.

- 2) Masonry shall only be cleaned of dirt or paint with non-acidic chemical solutions and water. Such solutions and water shall be sprayed at low to medium pressures never to exceed 400 pounds per square inch.

Comment: It is recommended that the cleaning technique first be applied to a 3 foot x 3 foot sample area located in an unobtrusive area of the wall(s) to demonstrate that the cleaning technique will be non-damaging.

B] Exterior Masonry Walls and Paint

- 1) A masonry wall that has been painted may be repainted. The new paint shall be a flat or satin paint.
- 2) Brick at public façades should be returned to the original brick color for the building by:
 - (a) Paint remover,
 - (b) Repainting to a brick color,
 - (c) Repaint to match the existing color.
- 3) The painting of unpainted stone walls is permitted with flat or satin, not gloss or semi-gloss.
- 4) The painting of unpainted brick walls is prohibited. The painting of unpainted windowsills in a brick facade is prohibited

C] Tuckpointing Exterior Masonry Walls

Comment: Tuckpointing of masonry walls is of the utmost importance in keeping the wall watertight while retaining the original appearance of the wall.

- 1) Existing mortar that is to be removed shall be removed with great care so as to not damage the brick, whether hand tools or power tools are used.

Comment: Power tool usage easily chips and damages masonry.

- 2) Tuck-pointing mortar shall be mixed nominally in the proportions specified as ASTM Type N. This is a mortar with 1 to 1-1/2 parts lime to each 1 part Portland cement, and 2-1/4 to 3 parts sand for each part of combined cementitious materials. An example mix would be 1 part cement, 1-1/4 parts lime, and 6 parts sand.

Comment: In the natural movement of a building, mortar that is too hard will spall, chip or break the adjacent masonry.

- 3) The color of the mortar shall match the majority of the mortar currently existing in the wall.

Comment: The color of mortar that does not have color pigment added is affected by the color and coarseness of the sand. Typically white silica sand

will result in mortars of a lighter color while brown river sand will result in mortars of a darker color. Similarly, sand of a finer coarseness will result in mortars of a lighter color while coarser sands will result in mortars of a darker color. In each instance, the color of the mortar will not be clearly identifiable until it has dried and been washed. Mortar normally dries in thirty days and may be washed of residue by plain water and a stiff bristle brush.

- 4) Mortar shall be tooled to match the existing or original character of the joints. (See figure 8)

Comment: Common joints found within The District include: concave, v-grooved, and struck.

Comment: It is recommended that a 3 foot x 3 foot sample area located in an unobtrusive area of the wall be tuck-pointed in order to illustrate compliance with the above.

D] Reconstructed Exterior Walls (See figure 9)

Comment: Reconstructed masonry walls include the replacement of missing masonry within a wall and the reconstruction of a masonry wall that has collapsed.

Comment: Masonry includes brick, ornamental pressed brick and terra cotta.

- 1) Construction:
A reconstructed masonry wall shall be one of the following types of construction:
 - (a) Solid masonry, or;
 - (b) Concrete block back-up with masonry exterior, or;
 - (c) Masonry veneer (hand lain brick) on metal or wood studs.
 - (d) Mortar thickness and coursing shall match the original.
- 2) Material: One of the following materials shall be used:
 - (a) New or used masonry units that match the original in size, shape, color (variety and pattern of color), surface hardness and ornament.
 - (b) Replicas of original ornamental masonry units constructed of the materials outlined in Section 201.7: Cornices.
 - (c) Soft, "salmon" brick, of the kind intended for use on the interior of walls, shall not be used for any elevation exposed to weather.
 - (d) Used masonry units shall not be used if a checkered pattern will result when faces of the units that were not originally exposed are re-laid exposed, or when the faces have traces of previous construction including paint, plaster, mortar, tar, coal soot and/or other foreign

coatings. With a little patience and coordination, a new masonry unit that matches the original can usually be found.

E] Exposed Masonry Party Walls

Comment: Exposed masonry party walls were original interior walls that served as a fire barrier between adjacent buildings. Upon demolition of one of the buildings, one face of this wall, which may be constructed of soft interior brick, is left exposed. Exposed masonry party walls present two problems: 1) how best to protect the soft brick wall from deterioration and 2) how to improve the irregular face left by demolition.

- 1) One of the following methods of treating exposed masonry party walls shall be used:
 - (a) Replace the exterior wythe with a new wythe of hard brick. The new brick shall be similar in size and color to the original brick of the building's secondary façade, if it exists, or be similar in size and color to the secondary façade of an HME.
 - (b) Clean the exposed wall of any debris; replace any deteriorated areas, tuckpoint the entire wall, and apply a breathable, clear waterproofing product formulated for use on historic materials and approved by the Cultural Resources Office.
- 2) Stucco is strictly prohibited as a method of treating exposed masonry party walls.

202.2 Wood Siding (See figure 10)

Comment: Wood siding is typically found at the sides of dormers, enclosed porches, rear additions and occasionally an entire building within the district.

- A] Wood siding shall be painted.
- B] Replacement materials are limited to new wood siding that replicates the original in design, dimension and method of application.
- C] The sides of a dormer may be resided as provided in Section 201.6 (D).
- D] The following replacement materials are prohibited:
 - 1) Masonite, aluminum, steel and vinyl siding are prohibited.

202.3 Stone and Cementitious Stucco Façades

- A] Paint.
 - 1) Stone façades that have not been painted may be painted.
 - 2) Stone façades to be repainted shall be painted shall follow the guidelines in Section 202.1(B).
- B] Missing pieces of stone and missing or severely damaged façades shall be repaired or replaced with like stone, cementitious products designed specifically

for historic stone repair, or other material that replicates the original appearance of the stone.

Comment: Portland cement products are too hard for this use in terms of adjacent materials and will likely to cause damage to the façade in the future.

- C] When a new coat of cementitious stucco veneer is applied to a flat wall surface the following apply:
- 1) The stucco shall be scored or molded to replicate the pattern and detail of the original stonework.
 - 2) The setback of windows and doors shall be closely maintained.
 - 3) The detailing of corners and edges shall be as crisp as the original.
 - 4) All of the original design elements must be maintained and/or replicated when repairing stone or stucco elements.

203 WINDOWS

Comment: Windows of historic buildings are a very important part of a building's historic character. They are integral to a building's exterior and interior design, and are a critical element of the building's weather protection system. The character of a window is determined by its size, operation, sash material, configuration of muntins, and frame and frame moldings. The character of the material – as in a paintable one like wood – also establishes the character.

203.1 Windows at Primary Public Façades

- A] Windows at the primary public façades shall be one of the following:
- 1) The existing window repaired and retained.
 - 2) A replacement window that duplicates the original or an HME that meets the following requirements:
 - (a) All components are made of wood, including basement windows on the primary public façade.
 - (b) The profiles of jambs, brickmolds, mullions, muntins, sashes, frames and moldings shall replicate the original elements in dimension, configuration and position in the opening. If the original brickmold style is unknown, the replacement shall be “Thorton” style.
 - (c) Multiple sills and jamb liners are not acceptable.
 - (d) Replacement sill and jamb set within existing sills and jambs are not acceptable.
 - (e) The number of lights, their arrangement, size and proportion shall match the original.
 - (f) The method of opening shall be the same as the original.

B] Glass Types

- 1) Glass in windows shall be one of the following:
 - (a) Clear glass or other original glazing, or;
 - (b) Glass based on an HME; or
 - (c) Insulated glass with its exterior face set back from the exterior face of the sash to match the original dimension, with a minimum setback dimension of 3/8 inches if the original dimension is unknown.
- 2) Bathroom windows not on a primary public facade may be frosted clear glass. Historical examples include glue chip and machine textured glass.
- 3) The following glass types are prohibited:
 - (a) Tinted glass
 - (b) Reflective glass
 - (c) Glass block
 - (d) Plastic (Plexiglas)

C] The infilling of a window by any means is prohibited. The placing of a smaller window in the original larger opening is not allowed.

D] Storm Windows and Screens (See figure 13)

Storm windows and screens may be installed at the interior of primary public façade windows. Interior installation is required to preserve the exterior appearance of the window and its details. Interior storm windows can be of any material, but the area of glass or screen shall be no less than the area of glass in the historic window. The meeting rail of the storm or screen shall be in line with that of the window and no additional meeting rails are allowed.

E] New Window Openings

- 1) No new window opening shall be created.
- 2) No existing window opening shall be altered in length or width.

203.2 Windows at Secondary and Rear Façades

Comment: Owners are encouraged to repair and retain the original appearance, dimensions, proportions and details of original windows located at private façades. Where alterations are to be made, the guidelines of Section 203.2(C) and (D) are strongly recommended.

Comment: The performance of a window derives from a combination of the framing material, glazing, and installation and maintenance to avoid leaking around the frame. Low-solar-gain, Low-E glass is acceptable if non-reflective and untinted.

Windows shall comply with all of the restrictions outlined in 203.1 except as provided [herein in this Section 203.2.](#)

A] Replacement Windows

- 1) Replacement windows shall be constructed of the following materials:
 - (a) Materials outlined in 203.1
 - (b) Fiberglass and composite materials
 - (c) Metal clad wood
- 2) Replacement windows to be installed in secondary public façades that are within ten feet (10') of a public sidewalk shall be wood, as on the primary façade.
- 3) Vinyl is prohibited as a replacement material.

B] Glazing

- 1) Glass in windows shall be one of the following:
 - (a) Clear glass or other original glazing; or
 - (b) Glass based on an HME; or
 - (c) Insulated glass with its exterior face set back from the exterior face of the sash to match the original dimension, with a minimum setback dimension of 3/8 inches if the original dimension is unknown.
- 2) Double-glazed, low-solar-gain, Low-E glazing is permitted; tinted Low-E glazing is not.
- 3) Bathroom windows not on a primary public facade may be frosted clear glass. Historical examples include glue chip and machine textured glass.
- 4) The following glass types are prohibited:
 - (a) Tinted glass
 - (b) Reflective glass
 - (c) Glass block
 - (d) Plastic (Plexiglas)

C] Infilling Windows (See figure 16)

- 1) Windows that are to be abandoned on the interior shall be in-filled as follows:
 - (a) The window opening shall be closed with wooden shutters set within brick mold framing the opening, approximately 1 inches to 2 inches back from the face of the wall with the masonry opening left intact including the brick mold, sill and lintel;
 - (b) The window opening shall be bricked-in with brick set 2 inches to 3 inches back from the face of the wall with the masonry opening left intact including the sill, lintel and brick mold. The infill brick should

match the surrounding brick in size, color, texture, coursing and mortar composition, color, texture and tooling.

- (c) The window may remain with the addition of an interior window treatment to obscure the fact that it has been abandoned on the interior. The window shall remain operable to provide access to interior window treatment for repair or replacement.

D] New Window Openings:

- 1) New openings where no window existed before or existing windows to be made shorter or longer, shall meet the following:
 - (a) The existing window opening shall not be widened or narrowed.
 - (b) The width of new openings shall be the same as another original window opening existing on the same elevation of the building.
 - (c) Masonry jambs shall be toothed-in, not saw-cut.
 - (d) New lintels shall align with adjacent lintels.
 - (e) Sills and lintels shall match the appearance and configuration of the original materials of the adjacent sills and/or lintels.

E] Storm Windows and Screens (See figure 15)

Comment: Storm windows and screens may be installed at the interior or at the exterior. Interior installation is preferred to preserve the exterior appearance of the window and its details.

- 1) Materials:
 - (a) Exterior storm windows and screens shall be wood, fiberglass or aluminum clad. Wood shall be painted; aluminum shall be factory-painted or primed and painted in place.
 - (b) Vinyl storm windows are prohibited on the exterior of a building.
 - (c) Interior storm windows and screens may be made of any material.
- 2) Storm windows and screens shall also meet the following requirements:
 - (a) The dimensions of the area of glass or screen shall be no less than the area of glass in the window being protected.
 - (b) The meeting rail of the storm or screen window shall be in line with the meeting rail of the window being protected. Additional meeting rails are prohibited.
 - (c) In the case of an arched-head opening, the top rail of the storm window and/or screen shall match the profile of the window sash.

Comment: Doors, like windows, are an integral part of a building's Primary Public Facade. Primary entrance doors are one of the strongest first impressions of a building.

Comment: Door types found in the district are limited to a few different types. Doors of earlier Federal style buildings are simple in construction and without ornament save for four or six panels. Victorian doors are much more ornate, often with elaborate carvings, recessed panels or other architectural detailing and typically have a glazed area in the upper half to three quarters of the door. Glass in a Victorian door is typically etched, beveled or leaded. Stormer doors often accompany Victorian doors and are of similar design though usually without any glazed area.

204.1 Doors at Public Façades (See figure 14)

Comment: As used herein the term "doors" includes stormer doors.

- A] Doors shall be one of the following for the front entrance.
- 1) The original wood door restored, or;
 - 2) A new wood door that replicates the original, or;
 - 3) A new wood door based on an HME of the same size as the historic one.
- B] The following types of doors are prohibited:
- 1) Flush, hollow-core doors with or without applied moldings, and;
 - 2) Metal doors of any type, including aluminum storm doors, and
 - 3) Stormer doors that do not replicate an HME.
- C] Doors shall have one of the following finishes:
- 1) Paint, or;
 - 2) Hardwood doors may have a natural finish.
- D] Hardware
- 1) Original hardware shall be retained when existing. When a new door is installed or when hardware is missing at an original door, the new hardware shall be of a style, type and material consistent with an HME.
 - 2) Dead bolt locks are allowed, provided the new hardware shall be of a style, type, and material consistent with an HME.
 - 3) When entrance hardware of historic commercial properties or places of public accommodation have pinch and twist functions that are not accessible, the historic hardware shall be maintained while allowing the door to function as a push/pull operation during business hours.
 - 4) Automatic door opening mechanisms ~~may~~ shall be installed in a manner that does not harm historic materials.
- E] Placement

- 1) Setting doors forward or back from their original line of placement is prohibited. Double sills or jamb liners are prohibited. New doors shall precisely fit the existing opening. Wide swing hinges are permitted.
- 2) Existing side panels in the entrance alcove shall be retained.

F] Providing Accessibility

Comment: Entrances in historic buildings need to maintain an historic appearance yet are a key point for accessibility. The Cultural Resources Office, in consultation with the Office on the Disabled, will determine the extent to which minor alterations that provide for accessibility are acceptable under these Standards and which must be referred to the Preservation Board for approval as an exception to the Standards.

- 1) At entrances to commercial spaces and places of public accommodation, thresholds and door framing elements may be modified in conjunction with the use of wide-swing hinges to allow for a clear 32” wide opening.
- 2) Access to commercial spaces and places of public accommodation may require the installation of a ramp or sloped pavement. Such work shall not destroy historic fabric, though providing access to enter a rehabilitated space is a high priority and shall be provided if at all possible.
- 3) The use of a power door opener is encouraged to facilitate entry and may be necessary when landing cannot be provided at both the top and bottom of ramps.

204.2 Transoms at Public Façades (See figure 17)

Comment: A transom is the window over the top of a door and can be either fixed or operable.

- A] Transoms shall be maintained as part of the entry, following the guidelines in Section 203.1 (A thru D).
- B] Storm windows and screens at transoms shall follow 203.1(E).

204.3 Vehicular Doors

Comment: There are a number of historic vehicular entrances within the district. Today, these entrances may still retain their original use or may have been converted to other uses.

- A] The structural opening of an original vehicular door shall remain intact.
 - 1) Vehicular door openings in private secondary façades may be in-filled with a simulated vehicular door or brick infill as specified in 203.2(C).
- B] Doors

- 1) Doors shall be of one of the following types:
 - (a) The original door or a duplicate of the original door, or;
 - (b) A door based on an HME, or;
 - (c) A door constructed of car siding (tongue & groove; 2-3/4 inches x 5/8 inches).
- 2) A man door may be incorporated into the overall design of the door.
- 3) Doors of the following types are prohibited:
 - (a) Overhead garage doors made of aluminum, fiberglass or steel.
- 4) Method of operation shall be one of the following:
 - (a) The original method of operation.
 - (b) Overhead doors may be used where they did not originally exist if they are clad with tongue and groove siding running vertically or if they replicate the appearance of an HME.
 - (c) The design and materials of vehicle doors shall not prevent the use of automatic door openers.

205 FOUNDATIONS (See figure 1)

Comment: The foundation creates both a structural and visual base on which a building rests. The foundation creates a strong visual line at the bottom of a building and provides a transition between the sidewalk or lawn and the building facade. The foundation block stone, concrete scoring or veneer stone must be in a "load bearing" pattern as based on an HME. The foundation is essential to the structural stability and weather resistance of a building.

Comment: Foundations within the district are typically white or grey limestone.

205.1 Paint

- A] Unpainted foundations may not be painted.
- B] Painted foundations shall follow guidelines for painted masonry. See Section 202.1(B).

205.2 Replacement Materials at Public Façades

- A] Foundation replacement materials shall be one of the following:
 - 1) New or re-used stone that matches the original in color, type of stone, size, finish, method of laying in a load bearing pattern.
 - 2) A veneer of the above applied to a different back-up material such as concrete or concrete block.

205.3 Surface Treatments at Public Façades

- A] Foundations shall not be parged (skim-coated) with stucco, concrete, mortar or other cement based materials.

Comment: Foundations that require tuck-pointing should be tuck-pointed to match the existing mortar in color, texture and composition (matching the color of the foundation stone).

206 APPENDAGES (See figure 1)

Comment: Only a few materials were historically used in the district in the construction of porches, stoops and steps. These materials included stone, brick, wood and occasionally various types of metal. Appendages were often the focus of architectural detailing and add to be individual character of a building.

206.1 Location and Type of Appendages

- A] Original appendages at the primary public façade shall not be removed or altered in configuration, location, or detail.
- B] At primary public façades, appendages may be reconstructed where there is evidence of their prior existence. Reconstructed appendages shall be rebuilt based on evidence at the building and an HME.

Comment: Evidence includes, but is not limited to, paint lines and profiles on the facade, indications of a former foundation, documented existence in terms of historical site plans and photographs.

- C] New Appendages:

Comment: New appendages are new construction where there is no evidence of an original appendage.

- 1) Are prohibited at primary public façades except as provided for in D].
 - 2) Shall be set back at least fifteen (15) feet from a primary public façade on a secondary public facade, unless the appendage is to be added to the rear elevation of a corner building. In this case, it shall be held back at least 1 foot.
 - 3) Shall be based on an HME.
 - 4) All façades of a new appendage shall utilize finish materials.
 - 5) Access to the main building from a new appendage shall be limited to a single door width opening in the original exterior wall at a secondary public façade.
- D] A discreet ramp to the main entrance may be constructed, but only in a manner that minimizes its impact on the historic building. The ramp shall not dominate the front of the building and shall not obscure character-defining architectural

features. The use of traditional landscape elements that incorporate a ramp or shields it from view is encouraged. No historic fabric from the entrance steps or stoop shall be removed or significantly impacted by the construction of a ramp.

- E] Handrails used for ramps and stairs may be slightly modified from a HME to afford accessibility.

206.2 Stone Elements

- A] Stone steps and porch elements shall be replaced only when necessary to ensure public and occupant safety.
- B] Steps and porch elements shall retain their original location and configuration.
- C] Stone steps and porch elements shall not be painted or receive any adhesively applied finishes.
- D] Replacement materials
 - 1) For architectural elements see the acceptable replacement materials listed under stone cornices in Section 201.7(B)(7).
 - 2) Replacement steps shall be one of the following
 - (a) New or re-used stone duplicating in shape, size and coloration of that being replaced.
 - (b) Precast concrete that replicates the stone in shape, size and coloration.

206.3 Wood Elements

- A] Reconstructed wood appendages shall be based on an HME. Materials shall be wood, except architectural details such as brackets, which may be of the materials listed under replacement materials for wood cornices in Section 201.7(B)(6)
- B] Reconstructed wood handrails shall be one of the following:
 - 1) A wood handrail based on an HME.
 - 2) The Souldard type handrail common to St. Louis.
Comment: The Souldard handrail may be modified for use on ramps and steps of commercial and public accommodation spaces and is recommended for use elsewhere where accessibility is to be achieved. (See figure 18)
- C] Wood handrails shall receive one of the following finishes:
 - 1) Paint.
 - 2) An opaque stain.
- D] Wood elements under this article shall also comply with Section 201.8.

206.4 Metal Elements

- A] Metal handrails and architectural detailing shall be of one of the types of metals or other replacement materials listed under Section 207.1(B).

207 ACCESSORIES

Comment: Accessories are architectural elements that add to the overall character of a building in smaller measure than the preceding appendage items. Accessories if chosen wisely can greatly enhance the historic quality of a building.

207.1 Wrought and Cast Iron Accessories (See figures 1 and 19)

Comment: These include balcony railings and cresting.

Comment: Wrought and cast iron accessories were once common in the district.

A] Existing wrought-iron and cast-iron accessories shall not be removed or altered in form.

Comment: Owners are encouraged to reconstruct balconies where they once existed especially if the original brackets are still in place.

B] Replacement Materials

1) New or re-used metal accessories based on an HME.

2) Other molded or cast material that replicates the appearance of the original.

207.2 Shutters at Public Façades (See figure 13)

Comment: Shutters were once very common within the district. Shutters were opened and closed daily to provide privacy, security and insulation. Windows that once had shutters often bear testimony to their former existence by extant hardware or markings in the brick molding.

Comment: Owners are encouraged to re-install shutters where they once existed.

A] Reconstructed shutters meet the following requirements:

1) Horizontally slatted and of wood construction unless an HME demonstrating otherwise is provided.

2) The size, height, and shape shall match the original sash.

3) Shutters must be hung on shutter hinges per original design. Shutters may not be fixed in a permanently closed position at primary public façades. They may be closed permanently at Public secondary façades as in the case of infilling a window. (See figure 16)

207.3 Security Bars at Public Façades (See figure 19)

Comment: Historically, security bars were only used at basement windows and consisted of ornamental ironwork placed to the exterior side of the window. This ornament added to the overall design of the facade.

A] Existing historic security bars and ironwork in front of windows at a Public Facade shall be retained where existing.

B] New security bars shall be added in accordance with the following:

- 1) New security bars added to basement windows at the primary public façades shall be added to the interior of the window unless based on an HME, but shall be done in a way as to not affect the safe egress from such windows.
- 2) New security bars added to other windows at the public façades shall be added to the interior and screened from the exterior by interior window treatment.
- 3) New security bars that are visible at the Public Facade shall be vertical in design, and based on an HME.

207.4 Awnings and Canopies

Comment: There is considerable historic evidence that the windows and doors of buildings within the district were once protected by awnings or canopies.

- A] New awnings and canopies shall be based on an HME and meet the following:
- 1) The same shape and size as the opening behind.
 - 2) Constructed of a fabric material.
 - 3) Lettering or numerals are prohibited, except as allowed in Section 207.7(A)(2)
- B] Metal awnings and canopies are prohibited.

207.5 Exterior Lighting at Public Façades

Comment: Light fixtures should be used to accent and highlight historic structures and to provide safety and security. Exterior lighting fixtures are generally not an original element of historic buildings and thus should be as simple and unobtrusive as possible. Only one (1) Exterior wall mounted lighting fixture shall be permitted on each facade of a building, except that one wall mounted fixture is allowed at each entrance doorway on a facade.

- A] Exterior wall mounted lighting fixtures shall be one of the following, and shall be mounted no higher than the top of the entrance door:
- 1) Based on an HME.
 - 2) A simple metal canister with a downward projecting light. The fixture shall be painted or anodized aluminum, to match the adjacent wall color.
 - 3) Metal bracket with a clear glass globe with a clear bulb. The metal bracket shall be painted or anodized aluminum to match the adjacent wall color, weathered copper or oiled bronze. Globes shall be fitted to the metal base and be without ornamental design.
- B] Lighting in entry alcoves shall be one of the following:
- 1) Based on an HME;
 - 2) Ceiling mounted and non-visible from the street;

- 3) A recessed can light in the ceiling of the entry.

207.6 Street Addresses at Public Façades

A] Numerals shall be Arabic.

B] Street addresses shall be one of the following:

- 1) At a transom
 - (a) Painted gold-leaf.
 - (b) Etched or leaded glass based on an HME.
 - (c) Stencil or decals to simulate gold leaf, with the design based on an HME.
- 2) On a door
 - (a) Etched or leaded glass based on an HME.
 - (b) Metal numerals, a maximum of 4 inches in height.
 - (c) Metal plaque, a maximum of 4 inches x 8 inches in size, with numerals integrally cast.
- 3) On landscape elements including walls, fences, carriage stones and steps
 - (a) Integrally carved in stone, a maximum of 4 inches in height.
 - (b) Metal numerals, a maximum of 4 inches in height.
 - (c) Metal plaque, a maximum of 4 inches x 8 inches in size, with numerals integrally cast.

Comment: Owners are discouraged from electing the following option due to the potential damage to the masonry by attachment devices.

- 4) On walls
 - (a) Metal numerals, a maximum of 4 inches in height.
 - (b) Metal plaque, a maximum of 4 inches x 8 inches in size, with numerals integrally cast.

C] The following types of street addresses are prohibited:

- 1) Plastic numbers attached to transom glass, doors, walls, steps, fences, roofs, light posts, mail boxes.

207.7 Signs at Public Façades

A] No non-appurtenant (off-site) signs are allowed.

Comment: Commercial signs are defined as those located at buildings that were originally built to house commercial uses; commercial signs at residential structures refer to installations at residential structures that have been converted to commercial or mixed-use.

B] Commercial signs

- 1) Commercial signs are otherwise regulated herein and by city, state and federal law.
- 2) Signs shall not project beyond the face of the building more than 36 inches.
- 3) A 6-inch maximum height for lettering on the apron of an awning is permitted.
- 4) Placard signs shall be metal or painted wood, and shall not exceed 800 square inches in size.
- 5) Signs shall not be applied above the second floor window sill line.
- 6) Sign lettering may be painted onto the flat fascia trim above storefront windows.
- 7) Signs may be painted on the storefront glass, with the stipulations that the height of letters does not exceed 6 inches and the lines of the sign are limited to 4.
- 8) Signs shall not be electric, except for decorative or “open” signs. Flashing lights are not allowed.
- 9) See Section 207.5 for exterior lighting restrictions.

C] Signs at residential structures shall be limited to no more than two signs, with the total area of all signs on a building to be no more than 100 square inches.

- 1) Signs shall be of one the following types when placed on walls:
 - (a) Metal or painted wood plaque, less than 100 square inches in size.
- 2) Signs shall not be placed on landscape elements including walls, fences, carriage stones and steps. Small historic markers and signs may be placed on pillars if based on an HME.

207.8 Mailboxes

A] Mail delivery shall be accomplished by one of the following:

- 1) A mail slot cut into an exterior door
- 2) A mounted mailbox not to exceed 12 inches tall by 12 inches wide by 6 inches deep, and painted to match adjacent surfaces.
- 3) If the exterior doors are recessed, the mailbox shall be mounted on the side panels or reveals.

208 MODERN CONVENIENCES AND UTILITIES

No modern conveniences shall be placed on the public facades or be located in the public yard of any property. Utility lines (gas pipe, telephone wire, television cable, power lines, water pipes, furnace exhausts, utility transmitters, gas meters, *etc.*) shall be

internal to the structure. These utilities shall enter the structure through the private façade.

209 STOREFRONTS

Comment: Storefronts are of particular importance in the district. As a part of the urban and cultural heritage of Lafayette Square, storefronts provided residents with a diversity of services conveniently located within walking distance of their homes. Historic storefronts still comprise the north side of the 1800 and 1900 blocks of Park and are also found at miscellaneous street corners.

Comment: Storefronts consist mainly of large, fixed pieces of glass as typified by figure 11. The glazing area normally extends from a knee high sill to ceiling height, with wood or metal frames supporting the store window and transoms. The area below the windows is often raised panels or molded panels.

208.1 Reconstructed Storefronts

A] Reconstructed storefronts shall meet the following:

- 1) The glazing shall be glass, either single or double pane, clear and fixed within a sash.
- 2) All exposed materials shall be finished.
- 3) Be based on an HME consistent with the building's original character.
- 4) As noted in Section 204.1(F), adjustments may be made to the reconstructed storefront dimensions to provide accessibility.

208.2 Storefront Conversion

A] Storefronts in buildings that are being converted to all residential use shall retain their original storefront configuration. A primary public facade shall not be altered in any way so as to disguise the original storefront use

209 CARRIAGE AND ALLEY HOUSES (See figure 2) SHOULD BE 210

Comment: Carriage and alley houses contribute to the district. These "working" buildings served as important adjuncts to the main residence on the lot and were considered necessary to the function of the larger house. Some carriage and alley houses are rich in architectural detailing and contribute to the overall visual character of the district.

Comment: The intent of this Ordinance is to protect and preserve the structural integrity of these two types of structures while recognizing that they are secondary structures.

209.1 Primary Façades (See figure 2)

The primary facade of an alley house is evident in the appearance of the building; it may face the alley or the street. The primary facade of a carriage house faces the main street and/or the rear of the main structure on the lot.

- A] The preceding standards for historic buildings apply to these primary façades properties, except as provided herein.
- B] Slate may be replaced with asphalt or fiberglass shingles.
- C] Plumbing vents, attic ventilation vents, and metal chimney or fireplace flues may be visible above the roof line.
- D] Window sash shall replicate the original, but may be of other materials such as aluminum clad or fiberglass.

210 REHABILITATION OF NON-HISTORIC BUILDINGS SHOULD BE 211

Comment: The definition of historic buildings as those erected prior to ~~1898-1919~~ leaves some buildings in a category of being erected in the district after that turning point.

- 210.1. The guidance standards in Sections 200-209 for the rehabilitation of historic buildings shall guide-govern work proposed for non-historic buildings, in particular the mandates that historic character be maintained through the retention of original features. These buildings shall not be remodeled to assume a more historic or more modern appearance.
- 210.2 The windows in these non-historic buildings shall be treated as windows of secondary and rear façades in Section 203.2.
- 210.3 All provisions of the Article 4: Site pertain to non-historic buildings as well.
- 201.4 As provided for in Sections 204.1(F) and 208.1, the rehabilitation of commercial entrances may include modifications in order to provide accessibility.

ARTICLE 3: NEW CONSTRUCTION AND ADDITIONS TO HISTORIC BUILDINGS

This article shall apply to new construction and additions to existing historic buildings. New residential use only buildings are addressed separately from new buildings with other uses or mixed use. The context of new construction for other uses is also identified as a critical factor. Additions are addressed separately.

300 GENERAL

This section recognizes the general guidelines for new construction that appear in the Lafayette Square Neighborhood Urban Plan (Dec. 5, 2001) and provides more specific standards.

- 300.1 When a specific item is not addressed for new construction, the standards for historic buildings shall be used.

301 ADDITIONS TO HISTORIC RESIDENTIAL PROPERTIES

- 301.1 Additions shall be compatible in massing and scale, proportions and solid to void ratio, and exterior materials and color to the existing residential building, and appear as a secondary portion of the residential property.
- 301.2 The existing building serves as an HME unless another property with an historic secondary rear wing is the model. In addition, the following requirements shall be met.
- A] No new additions shall be made extending from the primary public façade of buildings, except appendages, as described in 206.1(C)(3).
 - B] Additions must be set back 15 feet back from the primary public facade and extend from a secondary façade. Additions will have the massing and scale that keeps them secondary to the main residential structure. The design of additions will not give the appearance that the new portion was part of the original building be exactly replicating it, but will be compatible.
 - C] Additions may extend from a rear façade; they must be set back at least 1 foot from the secondary street façade or be the same width of an existing narrow rear wing.
 - D] The requirements for building materials, windows, other features, and roofs in Sections 303.5 to 303.9 apply to additions at secondary and rear façades.

302 NEW APPENDAGES

- 302.1 Appendages on primary or secondary public façades must be based on an HME.
- 302.2 Any porch or stoop on a secondary façade must be set back fifteen (15) feet from the primary facade.
- 302.3 The incorporation of accessibility at all primary entrances shall be considered in all new appendages. The addition of a ramp to a main entrance of an historic building, which may have an appendage, is addressed in Section 206.1 D.

303 NEW RESIDENTIAL CONSTRUCTION BASED ON AN HISTORIC MODEL EXAMPLE

303.1 Historic Model Example

In order to be consistent with the historic character of the district, each new residential building shall be based on an Historic Model Example (HME). This is understood to be one specific historic building and the design for a new building cannot draw upon elements from several buildings. The HME selected should be located in close proximity to the site of the new construction and represent a common property type. The property owner shall obtain concurrence from the Cultural Resources Office that the HME is appropriate for the site.

303.2 Site Planning

- A] Alignment and Setback

- 1) New construction and additions shall have primary façades parallel to such façades of adjacent buildings and have the same setback from the street curb.
- 2) In the event that new construction or addition is to be located between two existing buildings with different alignments to the street or with different setbacks, or in the event that there are no adjacent buildings, then the building alignment and setback that is more prevalent within the block front, or an adjacent block front, shall be used.
- 3) New residential buildings in an area with no existing historic buildings shall have a common alignment based on the historic pattern of that block front or an adjacent block front.
- 4) The existing grades of a site may not be altered beyond minor grading to affect water runoff.
- 5) The setback requirements are not intended to disallow construction of alley or carriage house type new construction.
- 6) Ancillary buildings shall be placed to be the least visible from public streets.
- 7) There shall be a sidewalk along all public streets. The sidewalk shall align with adjacent sidewalks in terms of distance from the curb. New and refurbished public sidewalks must be a minimum of 4 feet wide where possible and have a cross slope that provides an accessible route.
- 8) No new curb cuts for vehicles shall be allowed. Abandoned curb cuts will not be reutilized. Curb cuts for pedestrians at street intersections, mid-block crossings, passenger drop-off and loading zones, and similar locations shall be allowed.

B] Multiple unit new construction

- 1) No more than four attached townhouse units based on an HME may be constructed without a 36-inch-wide walk to the rear between the unit groups, unless the proposed development is based on an HME without such a walkway.
- 2) Every unit shall have a primary façade facing an existing street.
- 3) When several buildings, or a long building containing several units, are constructed on a sloping street; the building(s) shall step down the slope in order to maintain the height of the HME. The step in height shall occur at a natural break between units or firewalls.

303.3 Massing and Scale

- A] The massing of new construction shall be based on that of the HME selected to be comparable to that of the adjacent buildings or to the common overall building

mass within the block front. This massing is typically relatively tall, narrow, and deep.

- B] The HME and new building shall have a foundation raised above grade as a means to maintain compatibility in overall height with adjacent historic buildings.
- C] The HME and new building shall appear to be the same number of stories as other buildings within the blockfront. Interior floor levels of new construction shall appear to be at levels similar to those of adjacent buildings.
- D] The height of the HME and new construction shall be within two feet above or below that the average height within the block. Building height shall be measured at the center of a building from the ground to the parapet or cornice on a flat roof building, to the façade cornice on a Mansard roofed building, or to the roof eave on a building with a sloping roof.
- E] The floor-to-ceiling height of the first floor of HME and new construction shall be a minimum ten feet, and the second floor floor-to-ceiling height shall be a minimum of nine feet.

303.4 Proportions and Solid to Void Ratio

- A] The proportions of the HME and new construction shall be comparable to those of the HME and adjacent buildings. The proportional heights and widths of windows and doors must match those of the HME, which should be 1:2 or 1:3, the height being at least twice the width, on the primary façades.
- B] The total area of windows and doors in the primary facade of new construction shall be within 10 percent of that of the HME.
- C] The proportions of smaller elements, including cornices and their constituent components, of the HME will be replicated in the new construction.

303.5 Exterior Materials And Color

- A] Exposed foundations must be scored or cast to simulate load-bearing masonry mortar joints, or be faced with stone laid in a load-bearing pattern.
- B] As in the HME, there shall be a differentiation in all façades near the level of the first floor that defines the foundation as a base. The wall materials and /or the detailing at the base shall be distinct from that of the rest of that façade.
- C] The exterior wall materials of HMEs are a combination of stone and brick or all brick. Typically the primary façade material is different from the single material used for the side and rear walls.
- D] The materials of the primary façade of new construction shall replicate the stone or brick of the HME.
 - 1) A stone façade shall use the stone of the HME. It shall have smoothly-dressed stone cut into blocks with the same proportion as that of the HME, be laid with the same pattern, and have the same dimension of mortar joints.

The stone façade shall have the same depth of return on the secondary façades as the HME.

- 2) The use of scored stucco and cementitious materials to replicate the stone of the façade of the HME is permitted. As for stone façades, the return at the secondary façades shall replicate that of the HME.
 - (a) Brick shall replicate that of the HME as a pressed face brick with a smooth finish and a dark red color with only minor variations in color. Brick shall have these dimensions, 2 2/3" x 8" x 4", or be based on an HME. No brick façade will display re-used brick of varying colors and shades.
 - (b) Brick will be laid as in the HME, generally in a running bond, and its mortar joints will replicate, by type of façade, that of the HME in color, or be dark red or gray.
 - (c) Ornamental brick, stone or replica stone lintels, cornices, sills and decorative bands or panels shall be based on the HME. Window sills on brick primary façades shall be stone or pre-cast replica stone, based on the HME.

E] The HME shall determine the choice of the material used on the secondary and rear façades of a new residential building. Typically, common brick side and rear walls were combined with a face brick or stone street façade. Materials permitted for use on secondary and rear façades, therefore, shall be brick of suitable color, texture, and bond, and be pointed with mortar appropriate in color, texture and joint profile.

F] Siding of vinyl, aluminum, fiber cement, or wood of any type, style, or color is prohibited on any façade because of the requirement for an HME for new residential construction.

G] The materials identified above may be combined with modern construction techniques in the following ways:

- 1) The appearance of stone on a raised foundation may be created using stone veneer, parging with joint lines to replicate a load-bearing masonry pattern, or poured concrete that has the pattern of load-bearing masonry.
- 2) Brick, stone, and stucco scored to appear as stone may be installed as a veneer on exterior walls.

303.6 Windows

A] Windows in the HME and their sash will be the model for windows in new residential construction. The size and location of window openings in the HME will be replicated on the primary façade.

B] The profiles of the window framing elements – i.e. frames, sills, heads, jambs, and brick molds – will match the dimensions and positions of those in the HME.

C] Window Sash

- 1) Window sash shall match that of the HME in terms of operation, configuration (number of lights), and dimensions of all elements. The method of a window's operation may be modified on the interior in a way that does not change the exterior appearance and provides for accessibility.

D] Materials

- 1) Wood windows manufactured to match the characteristics of the HME are preferred on the primary façade. Any window sash that must be replaced in non-historic residential buildings constructed under these standards, or previous ones, shall meet these standards.
- 2) Factory-painted, metal clad wood and composite or fiberglass windows are acceptable for the primary façade if they meet the above requirements and are acceptable for secondary and rear façades.
- 3) Vinyl sash is prohibited.
- 4) All glazing will be non-reflective glass.
- 5) Windows may have double-glazed, low-solar-gain, Low-E glazing sash; tinted Low-E glazing is not permitted.

E] Arched window openings based on an HME must be filled with an arched sash set above the lower rectangular sash. A decorative arched sash must be based on the HME. For arched panels above rectangular windows, doors and transoms, the design of the eyebrow shall replicate that of the HME.

F] Windows in secondary and rear façades that do not face the street should have the proportions and size based on the HME. The operation of the window sash and material is not regulated, other than not being vinyl.

G] Bathroom windows in private secondary and rear façades may have frosted glass. Historical examples include gluechip and machine textured glass.

H] Storm Windows and screens, as on historic buildings, are allowed on the interior of primary public façade windows and on the exterior and interior of other façade windows. Other stipulations in Sections 203.1(D) and 203.2(D) apply here as well.

303.7 Doors

A] Doors on the primary and secondary street façades must be based on the HME and meet these requirements:

- 1) Be a minimum of 7 feet in height.
- 2) If the front entry door of the HME is set back from the façade, new construction must replicate this condition and replicate any paneled reveals of the HME.

- 3) All entry doors on street façades must have a transom, transom bar and transom sash, based on the HME.
 - 4) Slight modifications to the entrance design of the HME may be acceptable to provide 32-inch-wide openings, flush thresholds, and the use of swing clear hinges.
- B] Clear and non-reflective glazing shall be used in street façade doors and transom sash.
- C] Accessibility to residential buildings is encouraged and can be obtained through the selection of an HME, entrance design, the placement of actual floor levels, and other design choices.

303.8 Cornices

- A] The design of a primary façade cornice and all its elements shall be based on the HME. In the event that the measurements of the HME are not readily attainable, the following will be used:
- 1) Crown molding, if used must be a minimum of five and one quarter inches (5 ¼”) in height.
 - 2) Dentil molding, if used must be a minimum of four inches (4”) in height.
 - 3) Decorative panels or other moldings may be used between brackets or corbels only to replicate the selected HME.
- B] The space between brackets or corbels, and their height and proportions, shall replicate that of the HME.

303.9 Roofs

- A] The form of the roof must replicate the HME.
- B] Visible roof planes shall be uninterrupted with openings such as individual skylights, vents, pipes, mechanical units, solar panels, etc.
- C] Roofing Materials
- 1) Visible roofing material shall be limited to the following:
 - (a) Slate,
 - (b) Synthetic slate where slate is used on the HME,
 - (c) Asphalt or fiberglass shingles, standard three tab design of 235 pounds per square minimum construction,
 - (d) Standing seam, copper or prefinished sheet metal roofing only as gutters and ridges; all metal roofs are not allowed,
 - (e) Plate or structural glass on an appendage.
 - 2) Visible roofing material not permitted includes the following:

- (a) Wood shingles, or composition shingles resembling wood shingles or shakes
- (b) Roll roofing or roofing felts
- (c) Metal roofing
- (d) Vinyl or other polymeric roofing

D] Gutters and Downspouts

- 1) Gutters on the primary public façade must be incorporated into a cornice design based on an HME to the extent that the gutter is not visible as a separate element. No gutters can be placed across the primary public façade as individual elements. Gutters and downspouts shall be of one of the following materials:
 - (a) Copper; painted or allowed to oxidize.
 - (b) Galvanized metal, painted.
 - (c) Aluminum; finished as a non-reflective factory-finish surface.
 - (d) Plastic gutters and downspouts are prohibited.

E] Chimneys

- 1) Chimneys shall replicate those of the HME in location, size, material, and details.

F] Dormers

- 1) The design of dormers on primary and secondary street façades must be based on the HME.

304 NEW NON-RESIDENTIAL NEW CONSTRUCTION

304.1 New construction of non-residential buildings, and mixed use buildings, in the district shall be guided by overall compatibility with the historic buildings. This section makes a distinction between new non-residential construction that is infill for which the historical context is critical, and that on larger development sites, where scale, materials, and other factors determine compatibility.

304.2 The context of the built environment surrounding the site of infill new construction will determine how the proposed new building is compatible in the factors addressed below. In this case, appearing to have comparable floor heights, overall height, fenestration patterns, and other particular features are important. For larger development sites where no historic buildings will be adjacent to the new ones, buildings that are generally compatible with and use the prominent building materials found in the district have more latitude in some design elements.

304.3 An HME is not required for new non-residential construction due to the greater variety in non-residential buildings within the district, and areas within the district where housing is not found. However, new construction of combined commercial and residential property shall use a historic commercial block in the district as an HME.

304.4 New non-residential construction shall be accessible.

304.5 Site Planning For Non-Residential New Construction

A] Alignment and Setback

- 1) New non-residential construction in infill locations shall have a primary façade parallel to such façades of adjacent buildings and have the same setback from the street curb.
- 2) In the event that the infill site is located between two existing buildings with different alignments to the street or setbacks, the building alignment and setback that is more prevalent within the block front, or an adjacent block front, shall be used.
- 3) New non-residential buildings on large development sites where there are no existing historic buildings shall have a common alignment based on the historic pattern of an adjacent blockfront.
- 4) In all new non-residential construction, the primary façade shall contain an entrance.
- 5) There shall be a sidewalk along all public streets. The sidewalk shall align with adjacent sidewalks in terms of distance from the curb.
Comment: New and refurbished public sidewalks must be a minimum of 4 feet wide and have a cross slope that provides an accessible route.
- 6) Ancillary buildings shall be placed to be the least visible from public streets.
- 7) The existing grades of a site may not be altered beyond minor grading to affect water runoff.
- 8) New curb cuts are allowed for new non-residential construction on large development sites only.

304.5 Massing and Scale for Non-Residential New Construction

- A] The massing of new non-residential construction on infill sites shall be compatible with buildings in the vicinity and similar to buildings of the type in the district; i.e., a two-story commercial block will have a similar scale and massing, or appear to have, as existing buildings of that type in the district.
- B] The floor-to-ceiling height of the first floor of non-residential new construction in infill sites shall be a minimum ten feet, and the second floor floor-to-ceiling height shall be a minimum of nine feet.

- C] According to the neighborhood's *Urban Plan* (p. 25) no new non-residential buildings on larger development sites shall be taller than three stories.

304.6 Proportions And Solid To Void Ratio In Non-Residential New Construction

- A] The proportions of new construction on infill sites shall be comparable to those of adjacent buildings.
- B] The total area of windows and doors in the primary, public facade of new non-residential construction on an infill site shall be within 15 percent of that of the average of adjacent buildings.

304.7 Exterior Materials and Color in Non-Residential New Construction

- A] Exposed foundations on an infill site building must be scored or cast to simulate load-bearing masonry mortar joints, or be painted.
- B] The primary public façades of new non-residential construction shall be brick.
 - 1) Brick shall be a pressed face brick with a smooth finish and a dark red color with only minor variations in color. No brick façade will display re-used brick of varying colors and shades.
 - 2) Ornamental brick, stone or cast-stone lintels, cornices, sills and decorative bands or panels may be used.
- C] The material of the secondary façade(s) shall be brick.
- D] Siding of vinyl, aluminum, fiber cement material, or wood of any type, style, or color is prohibited on any façade that will be visible.

304.8 Windows in Non-Residential New Construction

- A] The fenestration pattern in new non-residential new construction will reflect common patterns in the district, in terms of percentage of voids to solids and vertically-oriented rectangular window openings. The operation of the window sash is not regulated.
- B] Vinyl sash is prohibited. The size of commercial windows may make wood sash unacceptable. Factory finished aluminum (anodized or painted) sash may be required for strength of a large commercial window.
- C] All glazing will be non-reflective and non-tinted glass.
- D] Windows of buildings on larger development sites may have double-glazed, low-solar-gain, Low-E glazing sash on primary facades.
- E] Bathroom windows in secondary and rear façades may have frosted glass.
- F] Storm windows and screens are allowed on the interior of primary public façade windows and on the exterior and interior of all secondary façade windows.

304.9 Roofs of Non-Residential New Construction

- A] Roofs of new non-residential construction shall be flat or pitched and shall not have any unusual, attention-getting form. Visible roof planes shall be uninterrupted with openings such as individual skylights or with solar panels.
- B] Visible roofing materials shall be asphalt or fiberglass shingles.
- C] Vents, pipes, and mechanical units shall not be visible.

305 NEW GARAGES

- 305.1 Garages shall be set within 10 feet of the alley line.
- 305.2 Garages shall be directly behind the main structure on the site. If site conditions prohibit this placement, then the new structure shall be positioned as close to this arrangement as possible.
- 305.3 Vehicular access shall only be from the alley. As per Section 303.2(A)(8), no new curb cuts are allowed and no abandoned cuts will be re-used in conjunction with a new driveway.
- 305.4 Garage doors shall be parallel to, and face, the alley.
- 305.5 Garages shall have a footprint of no more than 576 square feet, equal to a 24 foot by 24 foot two-car garage. Any auxiliary building with a larger footprint shall be considered a carriage house and shall be regulated under Section 306.
- 305.6 Garages shall have one of these two roof forms:
 - A] A gable roof placed with its ridge parallel to the alley and the ridge peak at twelve (12) feet or less.
 - B] A nearly flat roof edged by a shallow parapet.
- 305.7 Construction materials:
 - A] While there is no HME for a garage, this building type was traditionally built with a single exterior wall material: wood siding or brick. This traditional pattern will guide the selection of garage materials. The material selected shall be used on all four sides. The acceptable materials for new garages are:
 - 1) Brick of a dark red or brown untextured surface, laid with colored mortar;
 - 2) Wood, or cement fiber siding installed to simulate wood siding;
 - 3) Cement fiber panels.
 - B] A garage that sides on a public street or side yard shall be brick.
 - C] Vinyl siding is not allowed.

305.8 Carports and garage ports, a car port with a solid wall and garage door facing the alley, are not allowed in the district.

306 ALLEY HOUSES & CARRIAGE HOUSES

306.1 Some properties are large enough to accommodate a new auxiliary building other than a garage. New alley houses and carriage houses must be located adjacent to an alley, within 8 feet of it. They may not eliminate more than 50 percent of the private lawn area of the property.

306.2 A new alley house or carriage house must be based on an appropriate HME in the district, one selected to be secondary to the main residential building on the property. No new auxiliary building shall have the formality or ornate features found typically only on a main residence. The new building may replicate the HME or derive its overall character from it, but be a simpler version of it. This complementary version of the HME would be of the same scale and have the same exterior wall materials, but have fewer or simpler decorative architectural elements.

ARTICLE 4: SITE

400 GENERAL

This article applies to all buildings in the district.

401 SLOPE/GRADE OF PUBLIC YARDS

The historic slope of a public yard shall not be altered unless it has at some time been altered and is to be restored to its original configuration. A new retaining wall that complies with an HME may be installed. What appears to be a retaining wall or a free-standing wall based on a HME may be used in conjunction with the installation of an accessibility ramp in order to integrate the ramp into historic components of the district's public area landscape.

402 WALLS

402.1 Free Standing Walls

- A] Free standing walls are prohibited in front of the building line, unless the wall is used in the installation of a ramp, as provided for in Section 401. Free standing walls, as provided for in Section 401, shall not obscure character-defining architectural features. Any free standing wall must be located at least 12 inches to the rear of the plane of the primary public façade.
- B] The materials of free-standing walls shall be brick or stone laid in a load-bearing pattern and be based on an HME.

402.2 Retaining Walls

- A] New and reconstructed retaining walls shall be based on an HME.
- B] The exposed side of a retaining wall shall be vertical and may be cast in place concrete with the visual qualities of true stone. An HME is required.
- C] The top of the retaining wall shall be horizontal, and shall extend a maximum of 8 inches above the high point of the grade retained.

Comment: New and reconstructed retaining walls shall replicate the appearance of an historic wall. Thus stone or brick may be applied as a veneer to a concrete wall as long as the outward appearance meets the visual qualities of the HME.

- D] The following types of visible retaining wall materials are prohibited at public yards:
 - 1) Railroad ties
 - 2) Landscape timbers
 - 3) Concrete block of any type
 - 4) Cast-in-place or precast concrete
 - 5) Stucco that does not simulate cut stone

403 FENCES

Comment: Fences are a very important part of the streetscape within historic districts. Fences can frame a view of an individual's property, define public versus private ownership, and act in unison with other fences to add a sense of continuity and rhythm to the street.

403.1 Street Fences

- A] Street fences are restricted to a height of 42 inches or less when measured above the ground. An HME may be used as a reason for a variance. When placed atop a retaining wall, the height shall be measured from the top of the wall. A gate may be taller than 42 inches if based on an HME.
- B] The top of street fences shall be at the same level as adjacent street fences, or shall match the predominant level of street fences on the same block on the same side of the street.
- C] The top of street fences parallel to a sidewalk shall be horizontal, stepping the top at intervals as required to maintain the appropriate height.
- D] Street fences shall be metal and duplicate the proportion and scale of an HME . The HME fence shall be located in front of a building of similar age and type to the property under consideration.
- E] The following types of street fences are prohibited within the district:

- 1) Wire Fences
- 2) Chain link fences
- 3) Vinyl fences
- 4) Wood fences
- 5) Concrete or stucco fences

403.2 Privacy Fences

- A] Privacy fences must be placed at least 12 inches behind the plane of the Primary façade and be parallel to the street that façade faces.
- B] Privacy fences are restricted to a height of 72 inches or less when measured above the ground. When placed atop a retaining wall, the height shall be measured from the top of the wall.
- C] Privacy fences shall be one of the following types:
 - 1) A reconstructed fence based on an HME.
 - 2) A fence with a face plane created by lattice of one consistent design, either placed at a 45 or 90 degree angle. The lattice shall be completely within a frame constructed of stiles and rails.
 - 3) A fence with the upper face plane created by lattice as described above and with the lower section of the wall constructed of boards placed vertically with no space or gaps between them. The structure of the fence shall be behind the public facade of the fence.
 - 4) A fence constructed of stone or brick only or in combination with wrought or other iron.
 - 5) 5) A fence constructed of boards placed vertically with no space or gaps between them. The structure of the fence shall be behind the public facade of the fence.
 - 6) A fence constructed of stone or brick in combination with types 2, 3, and 5.
 - 7) Metal fences as described in Section 403.1(D) are acceptable.
- D] The following types of Privacy fences are prohibited within the district:
 - 1) Wire Fences
 - 2) Chain link fences
 - 3) Vinyl fences,
 - 4) Wood lattice, except within a frame
 - 5) Concrete or stucco.

404 SIDEWALKS

*Comment: Many of the residential streets in the district have brick sidewalks that were installed in the **DATE**1980s. These sidewalks contribute to the historic landscape in the district and property owners are encouraged to retain the sidewalks and install brick sidewalks when the adjacent properties have brick sidewalks.*

404.1 Public sidewalks, existing and new, shall be exposed aggregate concrete or red paving brick.

A] When brick sidewalks are installed or reinstalled, they shall meet the following specifications to provide a stable, firm, slip resistant and sufficiently smooth surface to be a part of an accessible route.

404.2 Entrance sidewalks at a secondary public façade must extend to the street curb line.

404.3 Exterior handrails at steps located in a yard shall be one of the following:

A] A 1-1/2 to 2 inches square or diameter, black wrought-iron handrail of a simple outline with vertical baluster design.

B] Based on an HME.

C] New handrails where none have previously existed shall be installed adjacent to stone steps to avoid the need for impacting the stone with new holes. Replacement handrails may be installed in existing holes in the stone if possible; no new holes may be drilled in stone elements.

405 EXTERIOR LIGHTING AT PRIMARY PUBLIC FAÇADES

405.1 Lighting shall be one of the following:

A] Low fixtures of less than one foot in height.

B] Fixtures concealed within the landscape design or building features.

405.2 Security lighting is allowed if the fixtures are concealed within the landscape design and/or building features.

405.3 The following types of lighting are prohibited at primary public façades and in the public portion of the yard:

A] Lighting fixture mounted on a yard post,

B] Lighting fixture mounted on public façades except as allowed by 207.5,

C] Flood lighting of building façades, except as allowed by 405(B).

D] Extreme lighting that is inconsistent with a Victorian neighborhood.

406 LAWN SCULPTURE

Lawn sculptures, including fountains, are prohibited in public yards.

407 SWIMMING POOLS

Above ground and in-ground swimming pools shall not be visible.

408 SATELLITE DISHES

No satellite dishes shall be visible in the public yard.

409 MAILBOXES

No free standing mailboxes shall be visible in a public yard.

ARTICLE 5 DEMOLITION

Comment: Buildings that are deemed significant by Lafayette Square residents and Merit and High Merit by the Cultural Resources Office of the City of St Louis, without regard to chronological age, are considered significant to the character and integrity of the neighborhood. Demolition is strongly discouraged and strictly limited. "Demolition by neglect" will not be tolerated.

500 APPLICATIONS FOR DEMOLITION PERMITS

Comment: Demolition permits for buildings within historic districts are applied for at the St. Louis City Building Commissioner's Office and reviewed by the Cultural Resources Office.

- 500.1 An application for any demolition within the Lafayette Square Historic District shall include the following information:
- A] Date owner of building acquired the property
 - B] Written statement describing reasons for demolition or proof of hardship
 - C] Copy of St. Louis records indicating the date of construction of the building under consideration
 - D] Site plan of the property showing the relation of the building to the site and to adjacent structures
 - E] Black and white or color photographs, 3 inches x 5 inches minimum size, of each elevation of the building.

501 VALID REASONS FOR DEMOLITION PERMITS

The primary valid reason for granting a demolition permit is for the removal of an addition or alteration that is not original to the structure, in order to restore the original appearance.

502 INVALID REASONS FOR DEMOLITION PERMITS

502.1 The following are not valid reasons for granting a demolition permit:

- A] Deterioration by neglect, lack of maintenance or failure to properly secure and weatherize the building.
- B] Structural damage or deterioration.

Comment: Owners shall maintain their properties to the minimum standards of the City of St. Louis Building Code.

ARTICLE 6. VACANT BUILDINGS

600 Vacant buildings shall be protected from deterioration as follows:

- A] Windows and doors that are not weather-tight, at all floor levels, and at all façades, shall be covered by minimum ½-inch exterior grade plywood. The exterior face of the plywood shall be stained or painted. No lettering on the plywood shall be allowed. Plywood shall be maintained free of graffiti.
- B] The roof, gutter and downspouts shall carry the rain water to the ground, and away from the building. The roof shall be replaced or maintained to prevent any leakage.
- C] The vacant building shall be secured and maintained as to eliminate further deterioration and vandalism.

ARTICLE 7. BUILDING PERMITS

700 REQUIREMENTS

700.1 A building permit application or preliminary review request for new construction shall be accompanied by the following:

- A] Clear photographs or other illustration of the HME chosen to be following in the design of residential new construction
- B] Site Plan including the following:
 - 1) The footprint of the new construction as well as an outline plan of the structures to each side of the site and across the street. The outline plan shall be extensive enough to indicate setback patterns on which the new construction is based.
 - 2) The plan shall indicate all existing and proposed site elements including but not limited to: parking; sidewalks; fencing; landscaping; lighting; ancillary buildings or structures; services (loading for commercial structures, refuse collection); and free standing signs.

- C] A grading plan with existing and proposed contours shall accompany the permit application for new construction.
- D] Façades in Elevations
 - 1) All façades shall be shown in elevations, with dimensions, and shall include an outline of existing, adjacent elevations to each side of all proposed construction. These existing outline elevations shall be supplemented by photographs.
 - 2) All materials, including facade, roof, windows, doors, foundations, steps, shall be noted on the elevations.
- E] Plans:
 - 1) Plans of all floor levels will note all dimensions and materials.
 - 2) Plans will include proposed placement of all external utilities (gas meter, transmitter, power meter, water meter, telephone, television, furnace exhausts, water and gas pipes, etc.) and any proposed external modern conveniences.
- F] Sections
 - 1) Two intersecting full height wall sections shall be included with permit application. These sections shall note all dimensions and materials.
- G] Details
 - 1) Drawings of window and door jamb, sill and head details shall be included with permit application for all proposed windows and doors of the primary facade. These details shall note all dimensions and materials.
 - 2) Cornices, eaves, gutters, downspouts, dormers, appendages, accessories, steps and all elements shall be detailed.

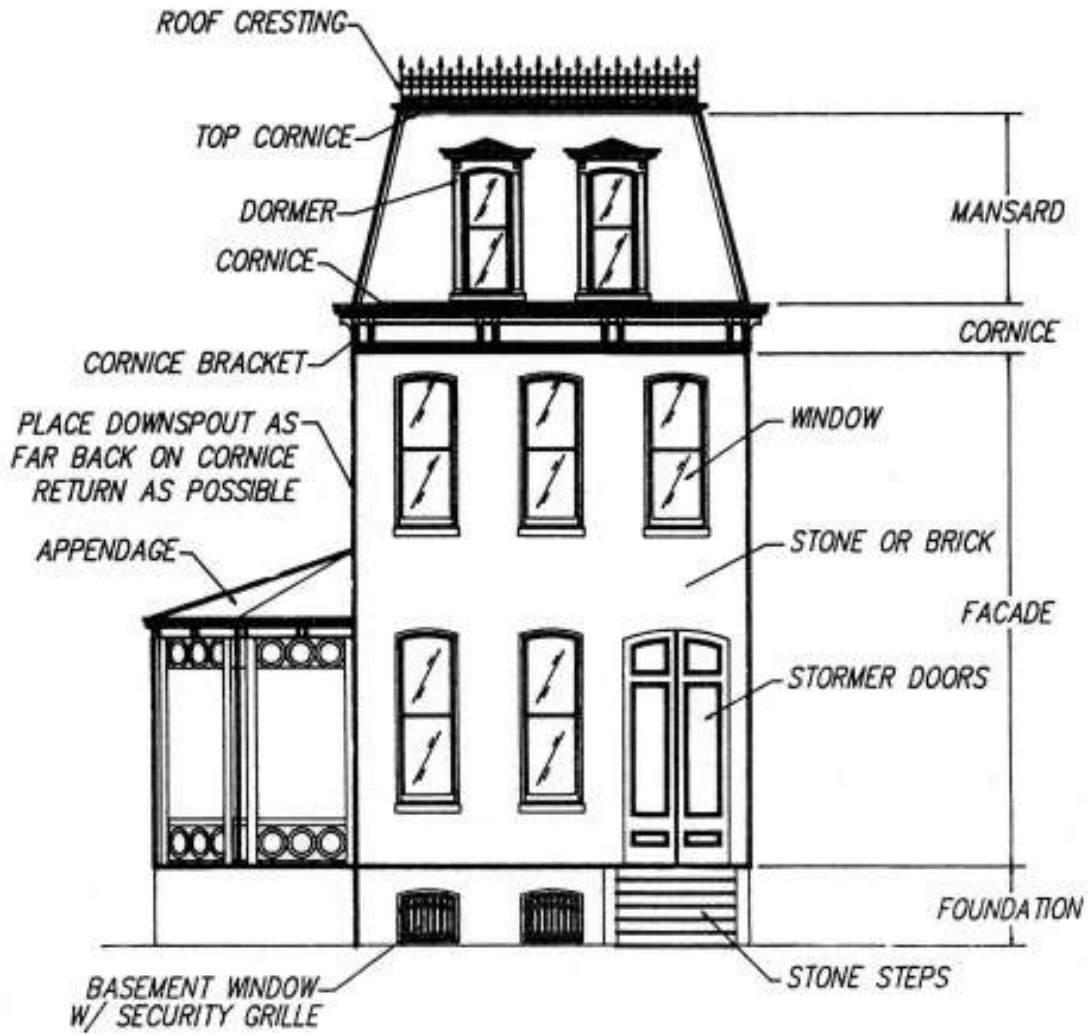

PUBLIC FACADE
2ND EMPIRE TOWNHOUSE
FIGURE 1

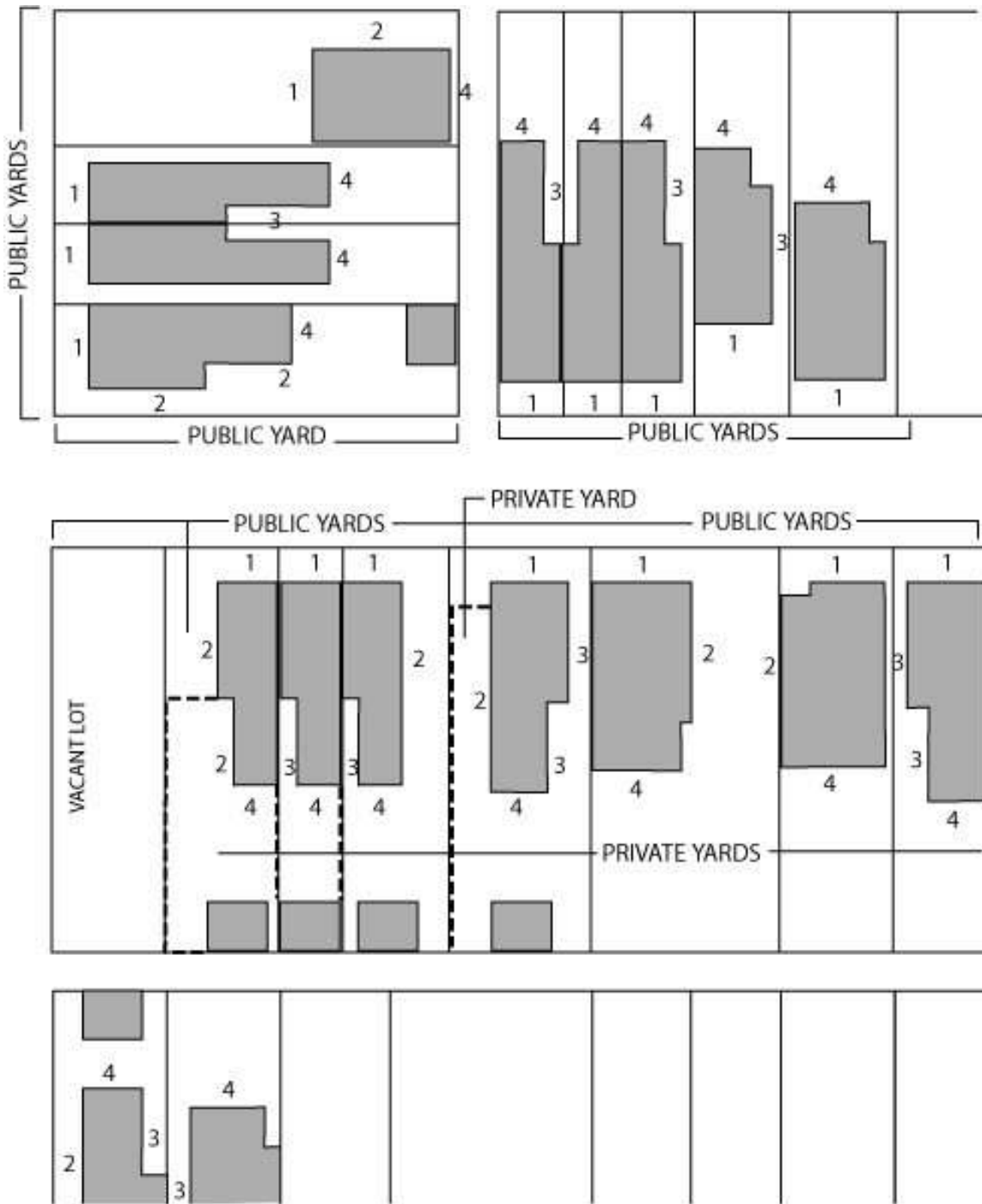

- 1 - PRIMARY PUBLIC FACADE
- 2 - SECONDARY PUBLIC FACADE
- 3 - SECONDARY PRIVATE FACADE
- 4 - REAR FACADE

- PRIVACY FENCE
- LOT LINE

FACADE TYPES
FIGURE 2

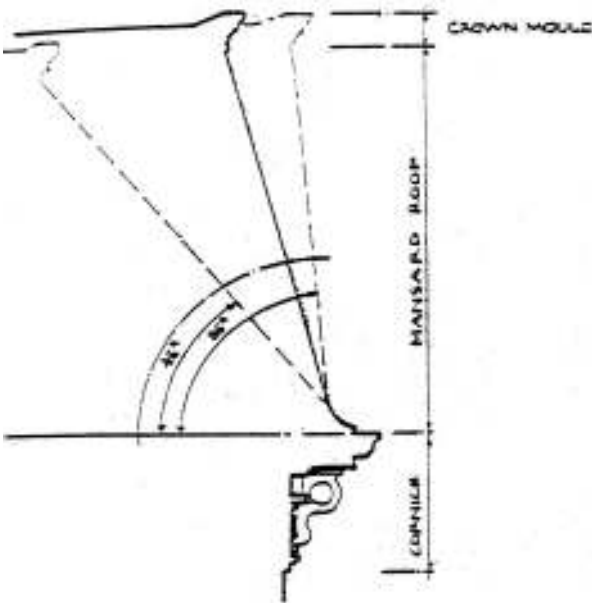

MANSARD SECTION
FIGURE 3

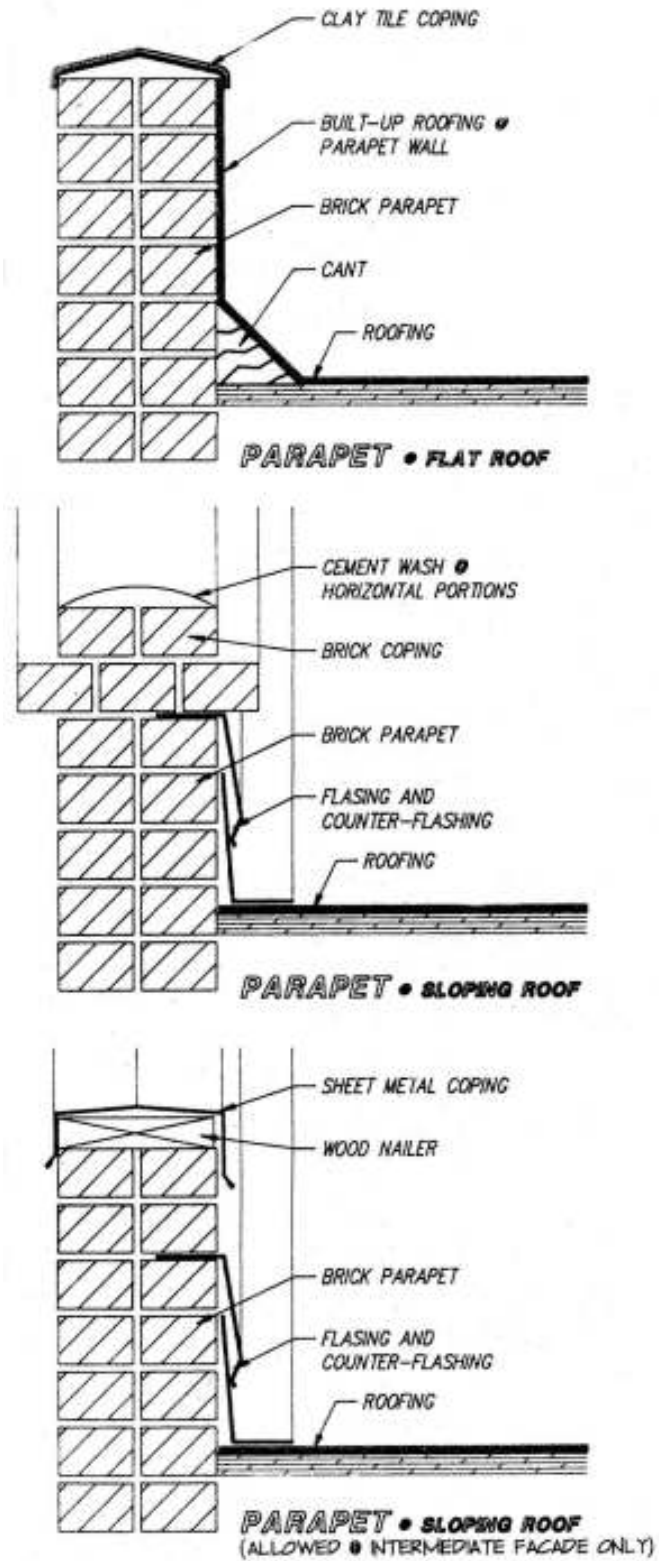

PARAPETS
FIGURE 4

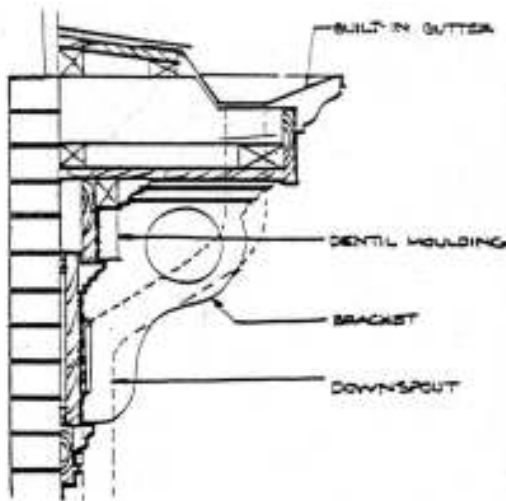

CORNICE DETAIL
 FIGURE 5

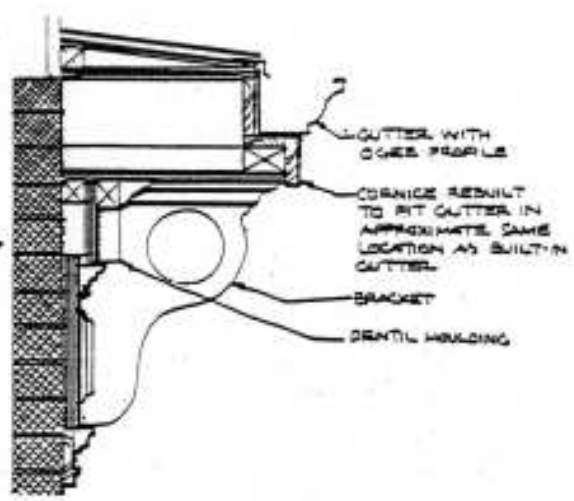

CORNICE DETAIL
 FIGURE 6

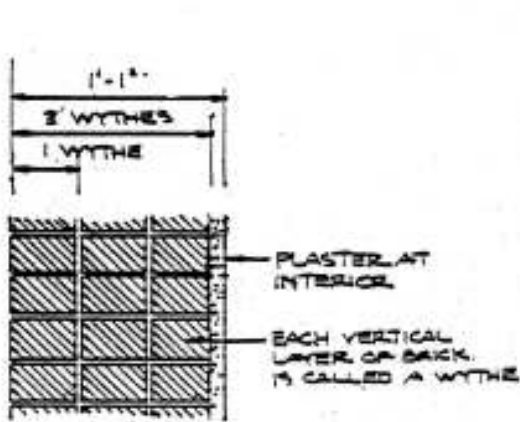

3 WYTHE WALL
 FIGURE 7

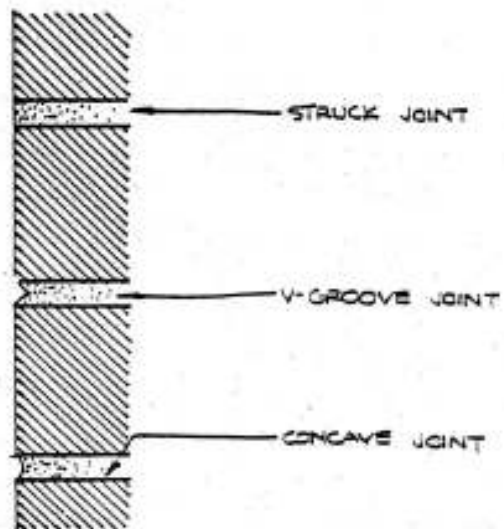

TYPICAL MASONRY
 JOINTS
MORTAR JOINTS
 FIGURE 8

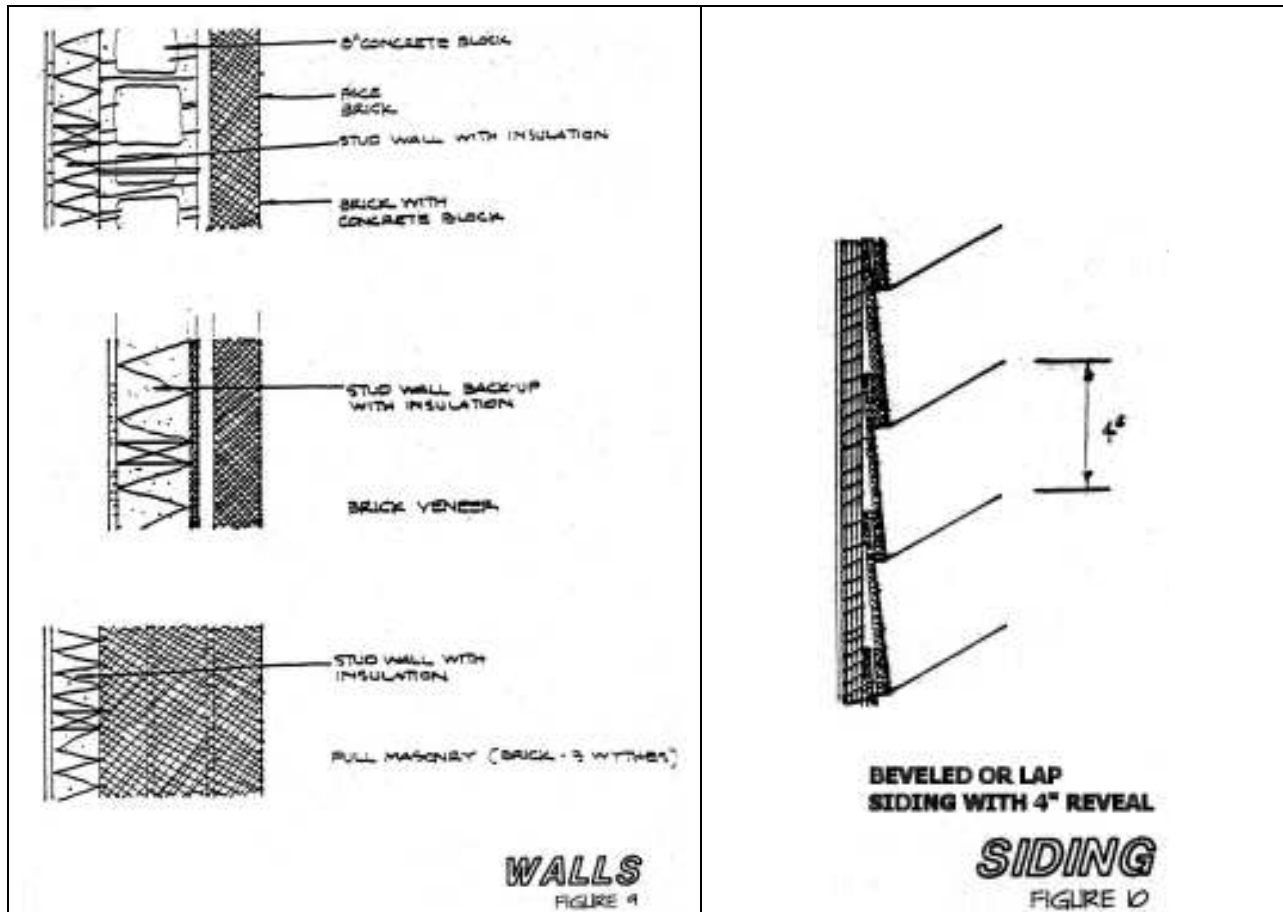

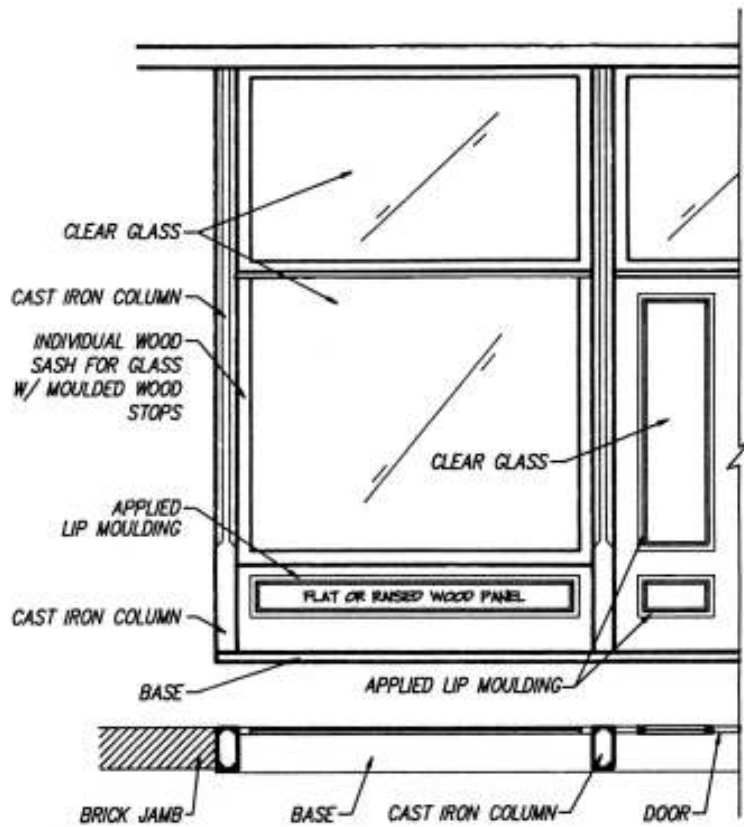

STOREFRONT DETAIL
 FIGURE 11

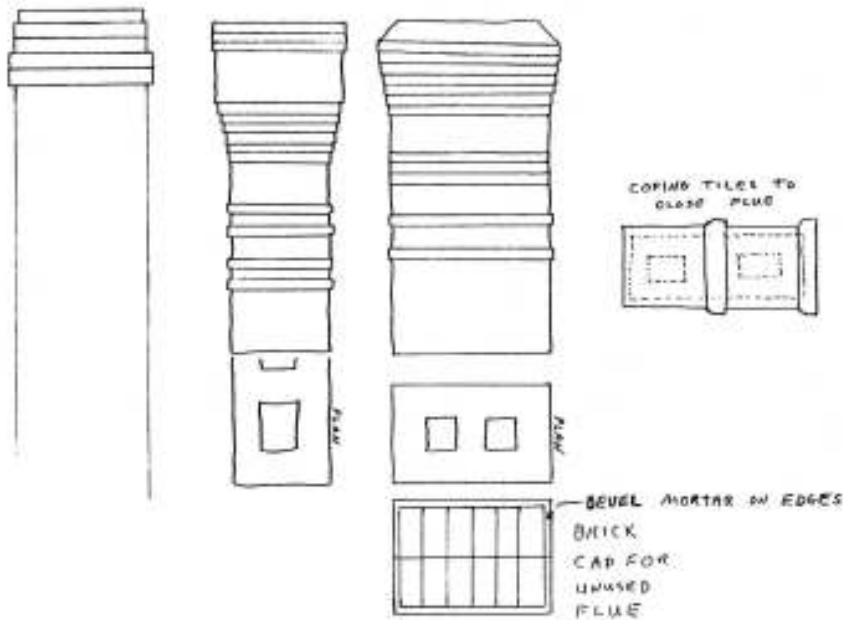

CHIMNEY TOPS
 FIGURE 12

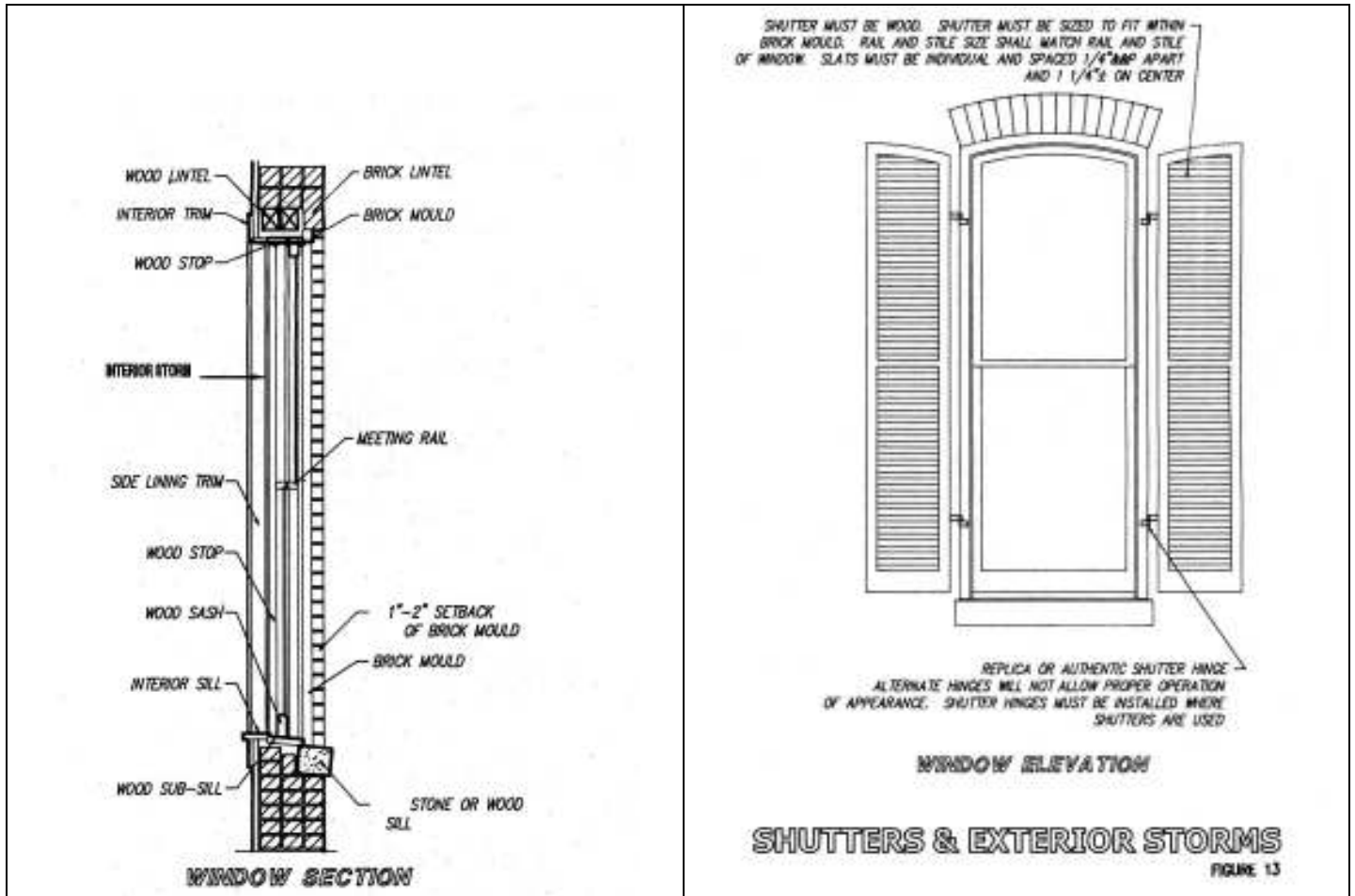

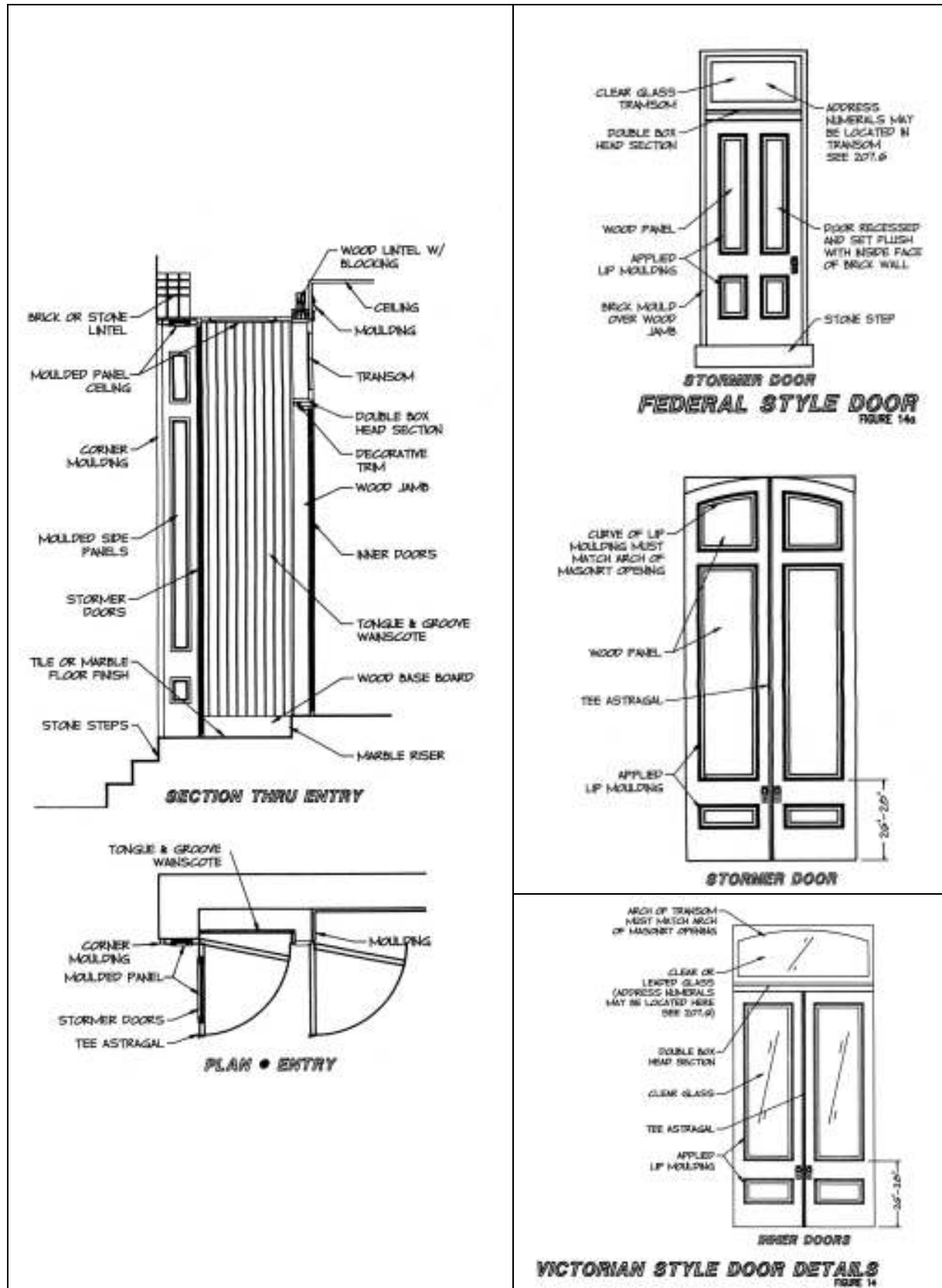

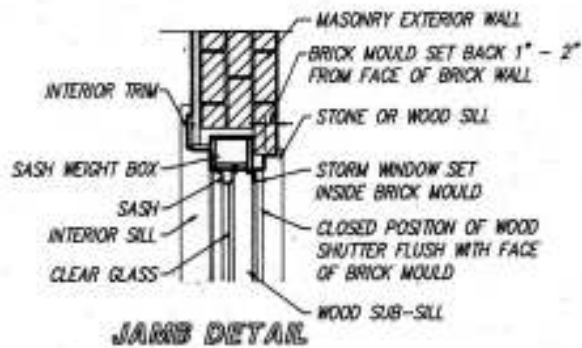

EXTERIOR STORM WINDOW
 FIGURE 15

NOTE: SEE FIGURE 13 FOR INFILL OF
 EXISTING WINDOW OPENING WITH
 SHUTTERS

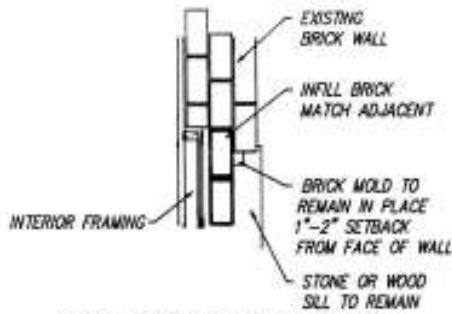

WINDOW HEAD SECTION

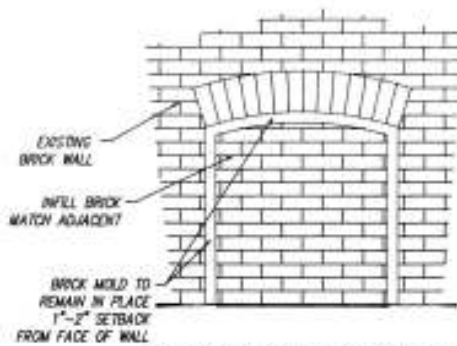

**WINDOW HEAD ELEVATION
 BRICK INFILL
 OF EXISTING WINDOW OPENING**
 FIGURE 16

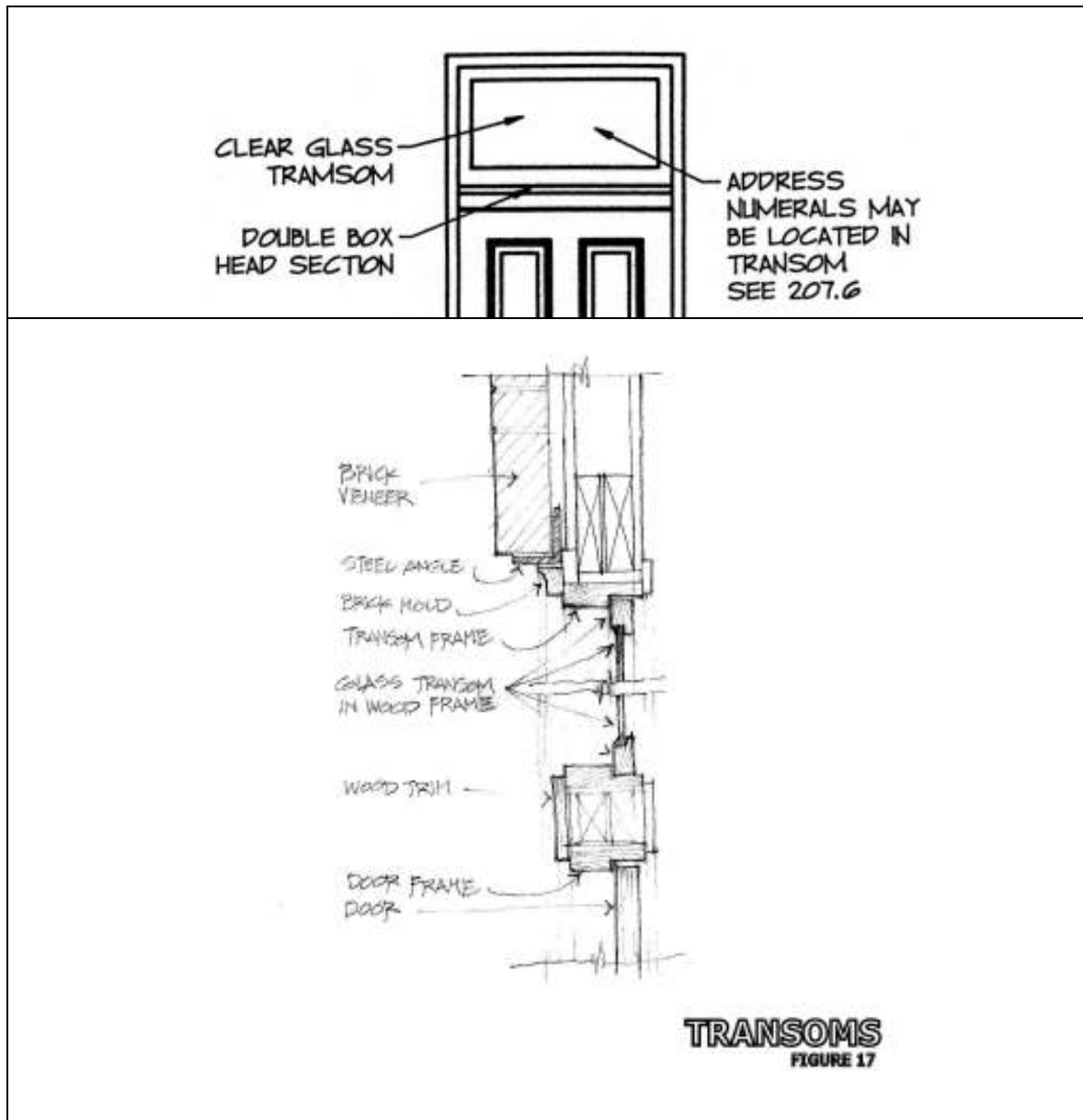

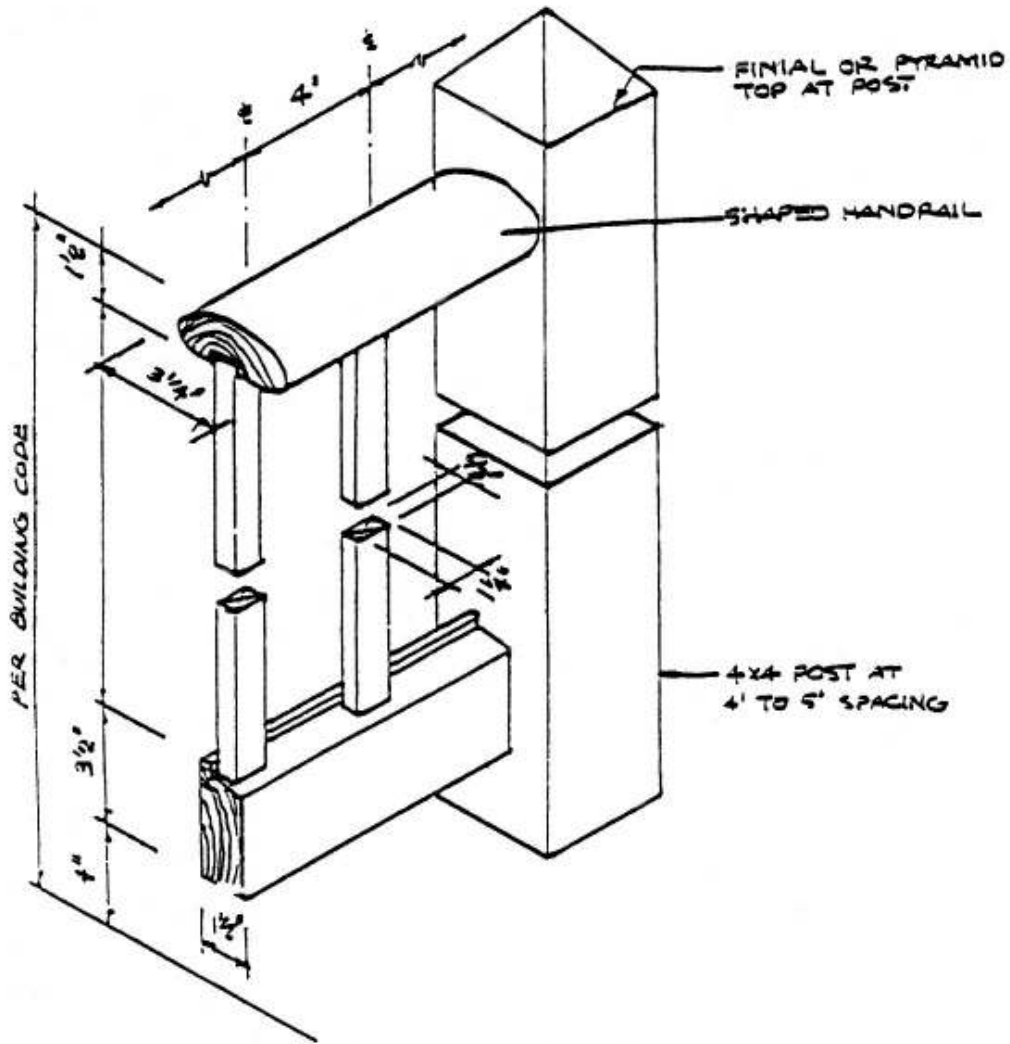

SOULARD RAIL
FIGURE 18

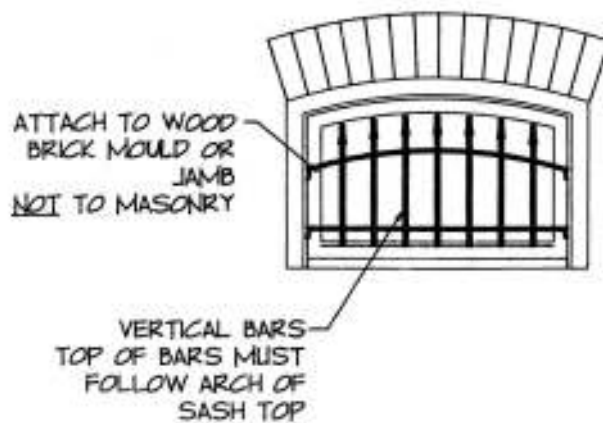
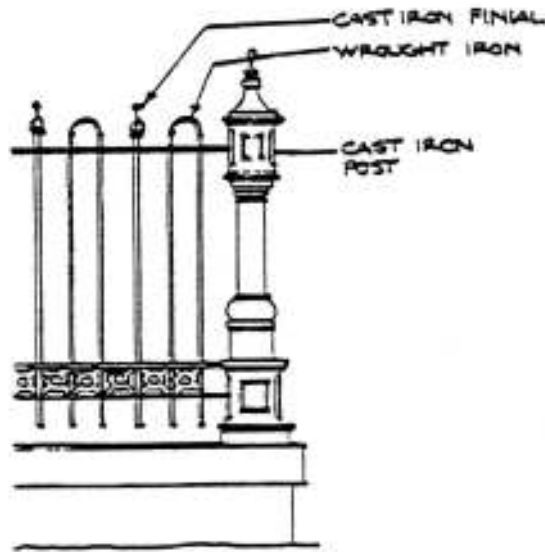
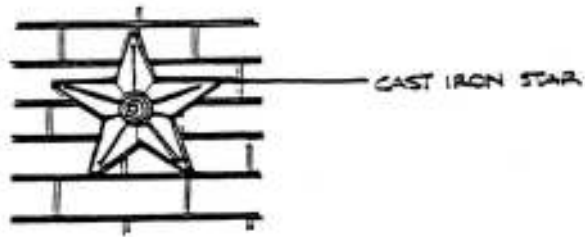

IRON ELEMENTS
FIGURE 19

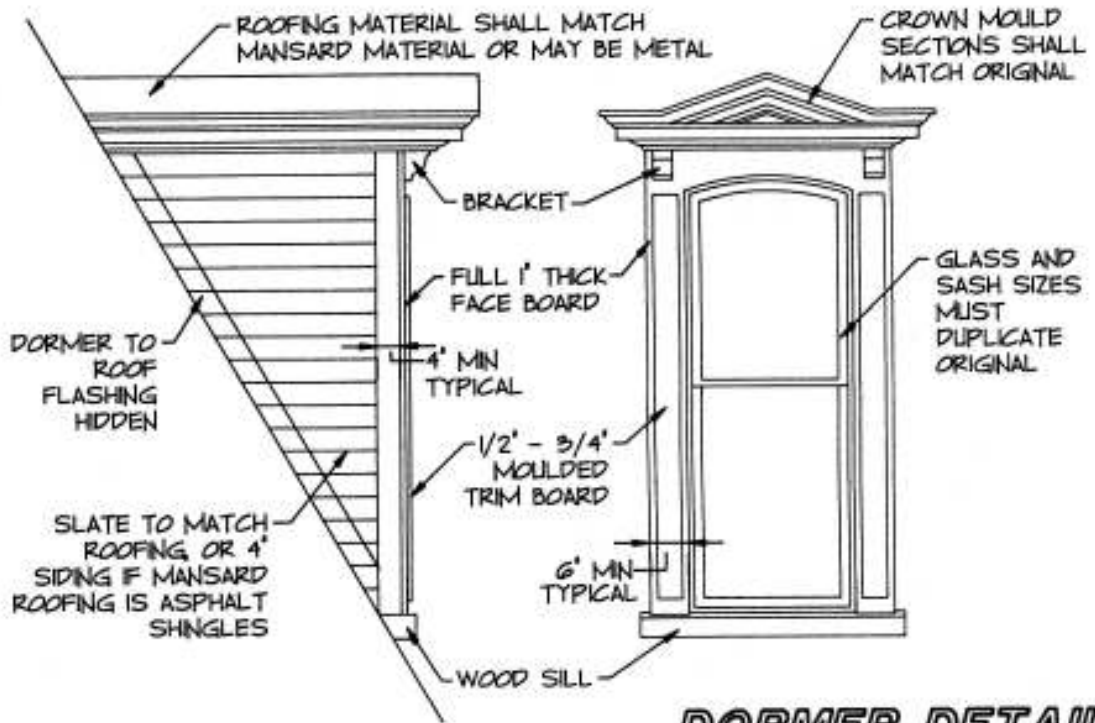

DORMER DETAIL
FIGURE 20